

Washer-Extractors

Cabinet Freestanding

Refer to Page 9 for Model Identification

Installation/Operation/Maintenance

Original Instructions

Keep These Instructions for Future Reference.

(If this machine changes ownership, this manual must accompany machine.)



www.alliancelaundry.com

Part No. D1598ENR6
December 2015

Table of Contents

Safety Information.....	5
Explanation of Safety Messages.....	5
Important Safety Instructions.....	5
Safety Decals.....	7
Operator Safety.....	7
Introduction.....	9
Model Identification.....	9
Delivery Inspection.....	10
Replacement Parts	11
Customer Service.....	11
Specifications and Dimensions.....	12
General Specifications.....	12
Machine Dimensions.....	15
Mounting Bolt Hole Locations.....	17
Floor Mounting Layout	18
Installation.....	19
Pallet Removal.....	19
Mounting Bolt Installation (If Required).....	19
Shipping Brace Removal.....	20
Machine Installation.....	21
Elevated Base Frame Installation with Existing Floor.....	21
Weighing System Installation - 18 kg - 28 kg / 40 lb. - 70 lb. / 180 - 280 L Models	21
Drain Connection.....	22
Drain Valve.....	23
Drain Pump, 7 kg - 8 kg / 14 lb. - 20 lb. / 65 L - 80 L Models.....	25
Venting.....	25
Water Connection Requirements.....	26
Water Reuse Connection.....	27
Reused Water Treatment.....	28
Water Reuse Tank Properties.....	28
Electrical Installation Requirements.....	29
Residual Current Device (RCD) - Models Outside of North America.....	30
Supply Protection Device.....	30
Supply Cable.....	31
Machine Protective Earth Connection and Equipotential Bonding.....	33
Input Power Conditioning.....	34
Input Voltage Requirements.....	34

Circuit Breakers and Quick Disconnects.....	34
Connection Specifications.....	35
Single-Phase Connections.....	35
Three-Phase Connections.....	36
Phase Adder.....	37
Thermal Overload Protector.....	37
Electrical Specifications - Models Outside of North America.....	37
Electrical Specifications - North American Models.....	45
Steam Requirements (Steam Heat Option Only).....	47
Steam Valve Installation.....	47
Supply Dispensing.....	48
Connection of External Liquid Supplies.....	48
Electrical Connection of External Liquid Soap Supply System.....	49
Operation.....	50
Operating Instructions.....	50
Power Cut.....	51
Automatic Door-lock Unlocking Module.....	51
Maintenance.....	52
Maintenance.....	52
Daily.....	52
Beginning of Day.....	52
End of Day.....	52
Quarterly.....	53
Every 6 Months.....	53
Care of Stainless Steel.....	55
Disposal of Unit.....	56
Disconnecting the Machine.....	56
Disposal of Unit.....	56

Safety Information

Explanation of Safety Messages

Precautionary statements (“DANGER,” “WARNING,” and “CAUTION”), followed by specific instructions, are found in this manual and on machine decals. These precautions are intended for the personal safety of the operator, user, servicer, and those maintaining the machine.

	DANGER
Indicates an imminently hazardous situation that, if not avoided, will cause severe personal injury or death.	

	WARNING
Indicates a hazardous situation that, if not avoided, could cause severe personal injury or death.	

	CAUTION
Indicates a hazardous situation that, if not avoided, may cause minor or moderate personal injury or property damage.	

Additional precautionary statements (“IMPORTANT” and “NOTE”) are followed by specific instructions.

IMPORTANT: The word “IMPORTANT” is used to inform the reader of specific procedures where minor machine damage will occur if the procedure is not followed.

NOTE: The word “NOTE” is used to communicate installation, operation, maintenance or servicing information that is important but not hazard related.

Important Safety Instructions

	WARNING
To reduce the risk of fire, electric shock, serious injury or death to persons when using your washer, follow these basic precautions:	
W023	

- Read all instructions before using the washer.
- Install the washer according to the INSTALLATION instructions. Refer to the Earthing (grounding) instructions in the INSTALLATION manual for the proper earthing (grounding) of the washer. All connections for water, drain, electrical power and earthing (grounding) must comply with local codes and be made by licensed personnel when required. It is recommended that the machine be installed by qualified technicians.
- Do not install or store the washer where it will be exposed to water and/or weather.
- To prevent fire and explosion, keep the area around machine free from flammable and combustible products. Do not add the following substances or textiles containing traces of the following substances to the wash water: gasoline, kerosene, waxes, cooking oils, vegetable oils, machine oils, dry-cleaning solvents, flammable chemicals, thinners, or other flammable or explosive substances. These substances give off vapors that could ignite, explode or cause the fabric to catch fire by itself.
- Under certain conditions, hydrogen gas may be produced in a hot water system that has not been used for two weeks or more. HYDROGEN GAS IS EXPLOSIVE. If the hot water system has not been used for such a period, before using a washing machine or combination washer-dryer, turn on all hot water faucets and let the water flow from each for several minutes. This will release any accumulated hydrogen gas. The gas is flammable, do not smoke or use an open flame during this time.
- To reduce the risk of an electric shock or fire, DO NOT use an extension cord or an adapter to connect the washer to the electrical power source.
- Do not allow children to play on or in the washer. Close supervision of children is necessary when the washer is used near children. This appliance is not intended for use by young children or infirm persons without supervision. Young children should be supervised to ensure that they do not play with the appliance. This is a safety rule for all appliances.
- DO NOT reach and/or climb into the tub or onto the washer, ESPECIALLY if the wash drum is moving. This is an imminently hazardous situation that, if not avoided, will cause severe personal injury or death.
- Never operate the washer with any guards, panels and/or parts removed or broken. DO NOT bypass any safety devices or tamper with the controls.
- Use washer only for its intended purpose, washing textiles. Never wash machine parts or automotive parts in the machine. This could result in serious damage to the basket or tub.
- Use only low-sudsing, no-foaming types of commercial detergent. Be aware that hazardous chemicals may be present. Wear hand and eye protection when adding detergents and chemicals. Always read and follow manufacturer’s instructions.

tions on packages of laundry and cleaning aids. Heed all warnings or precautions. To reduce the risk of poisoning or chemical burns, keep them out of the reach of children at all times [preferably in a locked cabinet].

- Do not use fabric softeners or products to eliminate static unless recommended by the manufacturer of the fabric softener or product.
- To avoid machine corrosion and component failure, do not use corrosive chemicals in the machine. Warranty claims related to damage caused by corrosive chemicals will be denied.
- Always follow the fabric care instructions supplied by the textile manufacturer.
- Loading door **MUST BE CLOSED** any time the washer is to fill, tumble or spin. **DO NOT** bypass the loading door switch by permitting the washer to operate with the loading door open. Do not attempt to open the door until the washer has drained and all moving parts have stopped.
- Be aware that hot water is used to flush the supply dispenser. Avoid opening the dispenser lid while the machine is running.
- Do not attach anything to the supply dispenser's nozzles, if applicable. The air gap must be maintained.
- Do not operate the machine without the water reuse plug or water reuse system in place, if applicable.
- Be sure water connections have a shut-off valve and that fill hose connections are tight. **CLOSE** the shut-off valves at the end of each wash day.
- Keep washer in good condition. Bumping or dropping the washer can damage safety features. If this occurs, have washer checked by a qualified service person.
- **DANGER:** Before inspecting or servicing machine, power supply must be turned **OFF**. The servicer needs to wait for at least 10 minutes after turning the power **OFF** and needs to check for residual voltage with a voltage meter. The inverter remains charged with high voltage for some time after powering **OFF**. This is an imminently hazardous situation that, if not avoided, will cause severe personal injury or death. Before starting inspection of the inverter, check for residual voltage across main circuit terminals + and -. This voltage must be below 30 VDC before the servicer can access the inverter for inspection.
- Do not repair or replace any part of the washer, or attempt any servicing unless specifically recommended in the user-maintenance instructions or in published user-repair instructions that the user understands and has the skills to carry out. **ALWAYS** disconnect the washer from electrical, power and water supplies before attempting any service.
- Disconnect the power by turning off the circuit breaker or by unplugging the machine. Replace worn power cords.
- Before the washer is removed from service or discarded, remove the door to the washing compartment.
- Failure to install, maintain, and/or operate this washer according to the manufacturer's instructions may result in conditions which can produce bodily injury and/or property damage.

NOTE: The WARNING and IMPORTANT SAFETY INSTRUCTIONS appearing in this manual are not meant to cover all possible conditions and situations that may occur. Observe and be aware of other labels and precautions that are located on the machine. They are intended to provide instruction for safe use of the machine. Common sense, caution and care must be exercised when installing, maintaining, or operating the washer.

Always contact your dealer, distributor, service agent or the manufacturer on any problems or conditions you do not understand.

NOTE: For European Union member states only: Electrical safety of the washers described in this manual is in compliance with the requirements of the European standard EN60204-1.

	DANGER
<p>Electrical shock hazard will result in death or serious injury. Disconnect electric power and wait ten (10) minutes before servicing.</p>	
W911	

	WARNING
<p>Dangerous voltages are present inside the machine. Only qualified personnel should attempt adjustments and troubleshooting. Disconnect power from the machine before removing any cover and guards, and before attempting any service procedures.</p>	
W736	

	WARNING
<p>Machine installations must comply with minimum specifications and requirements stated in the applicable Installation Manual, any applicable municipal building codes, water supply requirements, electrical wiring regulations and any other relevant statutory regulations. Due to varied requirements and applicable local codes, this machine must be installed, adjusted, and serviced by qualified maintenance personnel familiar with applicable local codes and the construction and operation of this type of machinery. They must also be familiar with the potential hazards involved. Failure to observe this warning may result in personal injury, property damage, and/or equipment damage, and will void the warranty.</p>	
W820	

IMPORTANT: Ensure that the machine is installed on a level floor of sufficient strength. Ensure that the recommended clearances for inspection and maintenance are provided. Never allow the inspection and maintenance space to be blocked.

	WARNING
<p>Never touch internal or external steam pipes, connections, or components. These surfaces can be extremely hot and will cause severe burns. The steam must be turned off and the pipe, connections, and components allowed to cool before the pipe can be touched.</p>	
SW014	

	WARNING
<p>Install the machine on a level floor of sufficient strength. Failure to do so may result in conditions which can produce serious injury, death and/or property damage.</p>	
W703	

	WARNING
<p>NEVER INTERFERE WITH THE SETTING OF THE DOOR HANDLE. NEVER TRY TO MODIFY THE SETTING OR REPAIR THE HANDLE! ANY INTERFERENCE WITH ITS SETTING MAY LEAD TO SERIOUS RISK FOR THE OPERATOR! A DAMAGED OR INCORRECTLY FUNCTIONING DOOR HANDLE MUST ALWAYS BE IMMEDIATELY REPLACED WITH A NEW ORIGINAL PART.</p>	
C014	

	CAUTION
<p>Models outside of North America - Machine with weighing system: Never carry load sensors by their cables. Avoid electric welding near the load sensors. An impact may cause permanent damage to the load sensor. Avoid unequal load distribution between the load sensors when putting the machine down. When the power of the machine is switched on, the system needs a ten (10) minute warm-up time. This is important when the power has been off for more than five (5) minutes. Ignoring warm-up may result in a major error in weighing.</p>	
W912	

Safety Decals

Safety decals appear at crucial locations on the machine. Failure to maintain legible safety decals could result in injury to the operator or service technician.

Use manufacturer-authorized spare parts to avoid safety hazards.

Operator Safety

	WARNING
<p>NEVER insert hands or objects into basket until it has completely stopped. Doing so could result in serious injury.</p>	
SW012	

The following maintenance checks must be performed daily:

1. Verify that all warning labels are present and legible, replace as necessary.
2. Check door interlock before starting operation of the machine:
 - a. Attempt to start the machine with the door open. The machine should not start.
 - b. Close the door without locking it and start the machine. The machine should not start.
 - c. Attempt to open the door while a cycle is in progress. The door should not open.

If the door lock and interlock are not functioning properly, disconnect power and call a service technician.

3. Do not attempt to operate the machine if any of the following conditions are present:
 - a. The door does not remain securely locked during the entire cycle.
 - b. Excessively high water level is evident.

Safety Information

- c. Machine is not connected to a properly grounded circuit.

Do not bypass any safety devices in the machine.

	WARNING
Operating the machine with severe out-of-balance loads could result in personal injury and serious equipment damage.	
W728	

Introduction

Model Identification

Information in this manual is applicable to these models:

HY105_HC-200	HY80_HC-200	HYN040F	HYU105F
HY135_HC-200	HYB180F	HYN055F	HYU135F
HY180_HC-200	HYG065F	HYN070F	HYU180F
HY20_HC-200	HYG080F	HYQ065F	HYU240F
HY240_HC-200	HYG105F	HYQ080F	HYU280F
HY25_HC-200	HYG135F	HYQ105F	HYW065F
HY280_HC-200	HYG180F	HYQ135F	HYW105F
HY30_HC-200	HYG240F	HYQ180F	HYW135F
HY40_HC-200	HYG280F	HYQ240F	HYW180F
HY55_HC-200	HYN020F	HYQ280F	HYW240F
HY65_HC-200	HYN025F	HYU065F	
HY70_HC-200	HYN030F	HYU080F	

SY105_QED	SYB180D	SYQ065A	SYU135D
SY105_QED-SELECT	SYG065A	SYQ065D	SYU180A
SY135_QED	SYG065D	SYQ080A	SYU180D
SY135_QED-SELECT	SYG080A	SYQ080D	SYU240A
SY180_QED	SYG080D	SYQ105A	SYU240D
SY180_QED-SELECT	SYG105A	SYQ105D	SYU280A
SY20_QED-SELECT	SYG105D	SYQ135A	SYU280D
SY240_QED	SYG135A	SYQ135D	SYW065A
SY240_QED-SELECT	SYG135D	SYQ180A	SYW065D
SY25_QED-SELECT	SYG180A	SYQ180D	SYW080A
SY280_QED	SYG180D	SYQ240A	SYW080D
SY280_QED-SELECT	SYG240A	SYQ240D	SYW105A
SY30_QED-SELECT	SYG240D	SYQ280A	SYW105D
SY40_QED-SELECT	SYG280A	SYQ280D	SYW135A
SY55_QED-SELECT	SYG280D	SYU065A	SYW135D
SY65_QED	SYN020D	SYU065D	SYW180A
SY65_QED-SELECT	SYN025D	SYU080A	SYW180D
SY70_QED-SELECT	SYN030D	SYU080D	SYW240A
SY80_QED	SYN040D	SYU105A	SYW240D
SY80_QED-SELECT	SYN055D	SYU105D	
SYB180A	SYN070D	SYU135A	

UY105_PROFORM	UY80_PROFORM	UYN040I	UYU105I
UY135_PROFORM	UYB180I	UYN055I	UYU135I
UY180_PROFORM	UYG065I	UYN070I	UYU180I
UY20_PROFORM	UYG080I	UYQ065I	UYU240I
UY240_PROFORM	UYG105I	UYQ080I	UYU280I
UY25_PROFORM	UYG135I	UYQ105I	UYW065I
UY280_PROFORM	UYG180I	UYQ135I	UYW080I
UY30_PROFORM	UYG240I	UYQ180I	UYW105I
UY40_PROFORM	UYG280I	UYQ240I	UYW135I
UY55_PROFORM	UYN020I	UYQ280I	UYW180I
UY65_PROFORM	UYN025I	UYU065I	UYW240I
UY70_PROFORM	UYN030I	UYU080I	

Delivery Inspection

Upon delivery, visually inspect crate, protective cover, and unit for any visible shipping damage. If signs of possible damage are

evident, have the carrier note the condition on the shipping papers before the shipping receipt is signed, or advise the carrier of the condition as soon as it is discovered.

Replacement Parts

If literature or replacement parts are required, contact the source from which the machine was purchased or contact Alliance Laundry Systems at +1 (920) 748-3950 for the name and address of the nearest authorized parts distributor.

Customer Service

For technical assistance, contact your local distributor or contact:

Alliance Laundry Systems

Shepard Street

P.O. Box 990

Ripon, WI 54971-0990

U.S.A.

www.alliancelaundry.com

Phone: +1 (920) 748-3121 Ripon, Wisconsin

Alliance International: +32 56 41 20 54 Wevelgem, Belgium

Specifications and Dimensions

General Specifications

Specifications	7 kg / 14 lb. / 65 L Models	8 kg / 20 lb. / 80 L Models	11 kg / 25 lb. / 105 L Models	14 kg / 30 lb. / 135 L Models	18 kg / 40 lb. / 180 L Models	24 kg / 55 lb. / 240 L Models	28 kg / 70 lb. / 280 L Models
Overall Dimensions							
Overall width, in. [mm]	27.95 [710]	27.95 [710]	31.29 [795]	31.29 [795]	38.18 [970]	38.18 [970]	38.18 [970]
Overall height, in. [mm]	43.89 [1115]	43.89 [1115]	48.22 [1225]	48.22 [1225]	55.51 [1410]	55.51 [1410]	55.51 [1410]
Overall depth, in. [mm]	29.13 [740]	31.10 [790]	31.29 [795]	37.20 [945]	38.18 [970]	43.50 [1105]	46.65 [1185]
Weight and Shipping Information							
Net weight, lbs. [kg]	375 [170]	408 [185]	463 [210]	563 [255]	838 [380]	948 [430]	1092 [495]
Shipping weight, lbs. [kg]	397 [180]	441 [200]	518 [235]	606 [275]	871 [395]	992 [450]	1135 [515]
Shipping dimensions (WxDxH), in. [mm]	29.53 x 33.01 x 49.02 [750 x 840 x 1245]	29.53 x 33.01 x 49.02 [750 x 840 x 1245]	32.87 x 33.01 x 52.95 [835 x 840 x 1345]	32.87 x 38.78 x 52.95 [835 x 985 x 1345]	40.35 x 39.96 x 61.02 [1025 x 1015 x 1550]	40.35 x 45.28 x 61.02 [1025 x 1150 x 1550]	40.35 x 48.23 x 61.02 [1025 x 1225 x 1550]
Wash Cylinder Information							
Cylinder diameter in. [mm]	20.87 [530]	20.87 [530]	24.40 [620]	24.40 [620]	29.53 [750]	29.53 [750]	29.53 [750]
Cylinder depth in. [mm]	12.01 [305]	13.78 [350]	13.78 [350]	17.72 [450]	16.14 [410]	21.46 [545]	24.41 [620]
Cylinder volume ft ³ [l]	2.3 [65]	2.6 [75]	3.7 [105]	4.8 [135]	6.4 [180]	8.5 [240]	9.9 [280]
Door Opening Information							

Table continues...

Specifications	7 kg / 14 lb. / 65 L Models	8 kg / 20 lb. / 80 L Models	11 kg / 25 lb. / 105 L Models	14 kg / 30 lb. / 135 L Models	18 kg / 40 lb. / 180 L Models	24 kg / 55 lb. / 240 L Models	28 kg / 70 lb. / 280 L Models
Door opening size, in. [mm]	13 [330]	13 [330]	16.14 [410]	16.14 [410]	18.11 [460]	18.11 [460]	18.11 [460]
Height of door bottom above floor, in. [mm]	13.74 [349]	13.74 [349]	13.46 [342]	13.46 [342]	18.77 [477]	18.77 [477]	18.77 [477]
Drive Train Information							
Number of motors in drive train	1	1	1	1	1	1	1
Motor Size, hp [kW]	1 [0.75]	1 [0.75]	1.48 [1.1]	2.01 [1.5]	2.95 [2.20]	4.02 [3.0]	4.02 [3.0]
Cylinder Speeds							
Wash, RPM	49	49	49	49	42	42	42
Extraction, RPM (350G)	N/A	N/A	N/A	N/A	N/A	N/A	915
Extraction, RPM (400G)	1165	1165	1075	1075	980	980	N/A
Heating							
Electric, kW	6 / 9 (4.6)	6 / 9 (4.6)	6 / 9 / 12	9 / 12	12 / 18	18	21.9
Steam, psi [bar]	15-116 [1-8]	15-116 [1-8]	15-116 [1-8]	15-116 [1-8]	15-116 [1-8]	15-116 [1-8]	15-116 [1-8]
Hot water, °F [°C]	90 [194]	90 [194]	90 [194]	90 [194]	90 [194]	90 [194]	90 [194]
Noise Emissions							
Wash sequence, dB	46	52	52	50	50	50	47
Extract sequence, dB	59	63	66	65	68	66	70
Floor Load Data							

Table continues...

Specifications and Dimensions

Specifi- cations	7 kg / 14 lb. / 65 L Models	8 kg / 20 lb. / 80 L Models	11 kg / 25 lb. / 105 L Models	14 kg / 30 lb. / 135 L Models	18 kg / 40 lb. / 180 L Models	24 kg / 55 lb. / 240 L Models	28 kg / 70 lb. / 280 L Models
Maximum static load on floor, lbs. [kN]	472 [2.1]	517 [2.3]	585 [2.6]	719 [3.2]	1102 [4.9]	1191 [5.3]	1304 [5.8]
Maximum dynamic load on floor, lbs. [kN]	405 ± 112 [1.8 ± 0.5]	428 ± 112 [1.9 ± 0.5]	495 ± 112 [2.2 ± 0.5]	607 ± 112 [2.7 ± 0.5]	899 ± 112 [4.0 ± 0.7]	1034 ± 112 [4.6 ± 1.1]	1124 ± 112 [5.0 ± 1.1]
Frequency of dynamic load, Hz	19.4	19.4	17.9	17.9	16.3	16.3	15.25
General Data							
Ambient Temperature, °F [°C]	41-95 [5-35]						
Relative Humidity	30%-90% without condensation						
Height above sea level ft. [m]	up to 3280 [up to 1000]						
Storage Temperature, °F [°C]	34-131 [1-55]						

Machine Dimensions

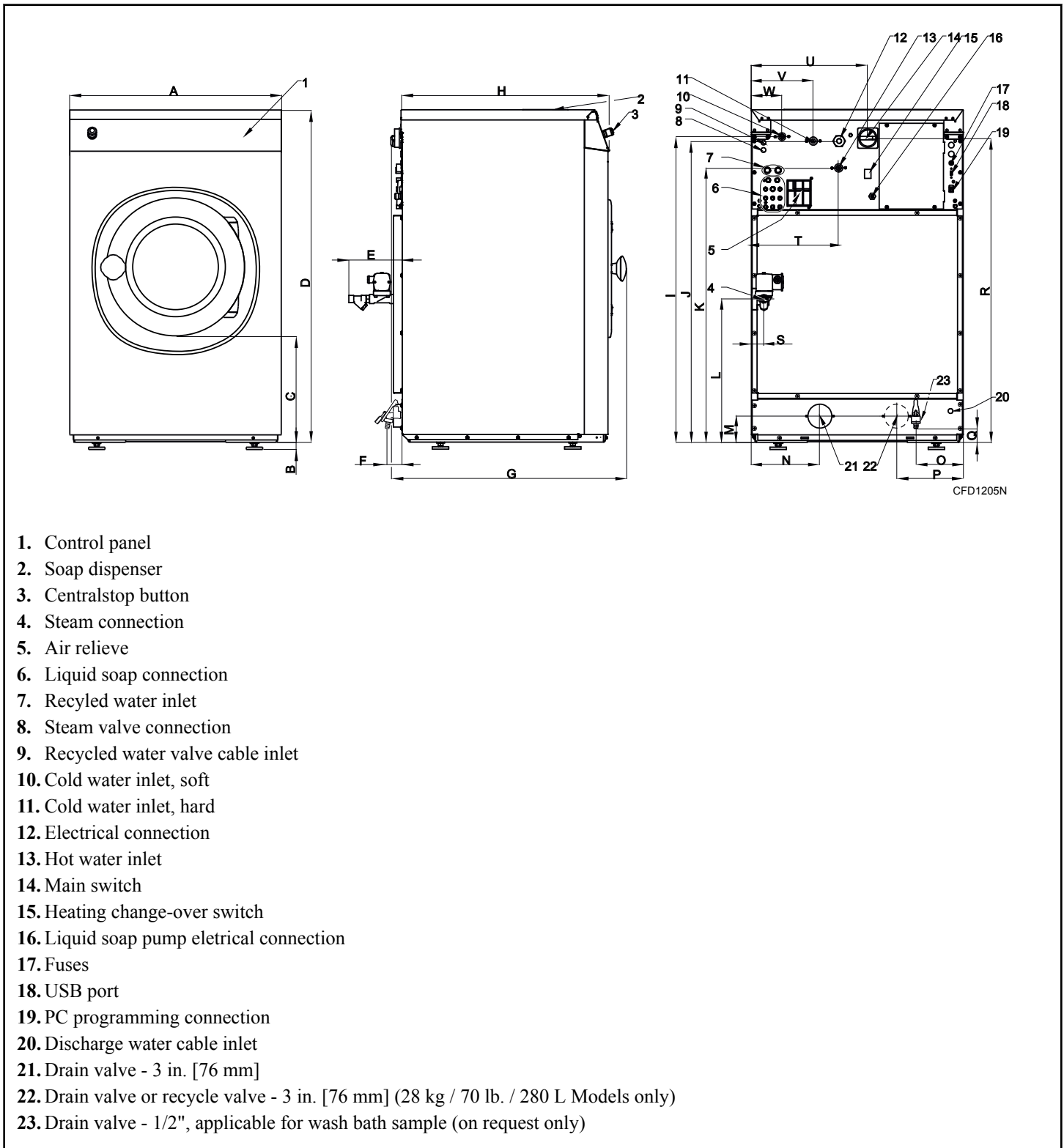

Figure 1

Specifications and Dimensions

Specifi- cation	7 kg / 14 lb. / 65 L Models, in. [mm]	8 kg / 20 lb. / 80 L Models, in. [mm]	11 kg / 25 lb. / 105 L Mod- els, in. [mm]	14 kg / 30 lb. / 135 L Models, in. [mm]	18 kg / 40 lb. / 180 L Models, in. [mm]	24 kg / 55 lb. / 240 L Models, in. [mm]	28 kg / 70 lb. / 280 L Models, in. [mm]
A	27.95 [710]	27.95 [710]	31.29 [795]	31.29 [795]	38.18 [970]	38.18 [970]	38.18 [970]
B	0.94 [24]	0.94 [24]	0.94 [24]	0.94 [24]	0.94 [24]	0.94 [24]	0.94 [24]
C	13.74 [349]	13.74 [349]	13.46 [342]	13.46 [342]	18.77 [477]	18.77 [477]	18.77 [477]
D	43.89 [1115]	43.89 [1115]	48.22 [1225]	48.22 [1225]	55.51 [1410]	55.51 [1410]	55.51 [1410]
E	7.08 [180]	7.08 [180]	7.08 [180]	7.08 [180]	3.54 [90]	3.54 [90]	3.54 [90]
F	1.89 [48]	1.89 [48]	1.89 [48]	1.89 [48]	1.89 [48]	1.89 [48]	1.89 [48]
G	29.13 [740]	31.10 [790]	31.29 [795]	37.20 [945]	38.18 [970]	43.50 [1105]	46.65 [1185]
H	25.43 [646]	27.40 [696]	27.40 [696]	33.31 [846]	34.49 [876]	39.80 [1011]	42.76 [1086]
I	40.11 [1019]	40.35 [1025]	44.68 [1135]	44.68 [1135]	51.96 [1320]	51.96 [1320]	51.96 [1320]
J	39.52 [1004]	39.76 [1010]	44.09 [1120]	44.09 [1120]	51.08 [1297.5]	51.08 [1297.5]	51.37 [1305]
K	35.98 [914]	36.22 [920]	40.55 [1030]	40.55 [1030]	47.83 [1215]	47.83 [1215]	47.83 [1215]
L	18.89 [480]	18.89 [480]	19.92 [506]	19.92 [506]	19.29 [490]	19.29 [490]	19.29 [490]
M	3.22 [82]	3.46 [88]	3.46 [88]	3.46 [88]	4.27 [108.5]	4.27 [108.5]	4.27 [108.5]
N	9.05 [230]	9.05 [230]	9.05 [230]	9.05 [230]	10.62 [270]	10.62 [270]	10.62 [270]
O	7.99 [203]	7.99 [203]	7.99 [203]	7.99 [203]	7.99 [203]	7.99 [203]	7.99 [203]
P	N/A	N/A	N/A	N/A	N/A	N/A	10.79 [274]
Q	2.64 [67]	2.64 [67]	2.64 [67]	2.64 [67]	2.64 [67]	2.64 [67]	2.64 [67]
R	40.15 [1020]	40.15 [1020]	44.48 [1130]	44.48 [1130]	51.77 [1315]	51.77 [1315]	51.77 [1315]
S	1.65 [42]	1.65 [42]	1.65 [42]	1.65 [42]	3.14 [80]	3.14 [80]	3.14 [80]
T	11.53 [293]	11.53 [293]	11.53 [293]	11.53 [293]	11.53 [293]	11.53 [293]	11.53 [293]
U	15.35 [390]	15.35 [390]	18.70 [475]	18.70 [475]	24.01 [610]	24.01 [610]	24.01 [610]
V	8.58 [218]	8.58 [218]	8.58 [218]	8.58 [218]	8.58 [218]	8.58 [218]	8.58 [218]
W	4.44 [113]	4.44 [113]	4.44 [113]	4.44 [113]	4.44 [113]	4.44 [113]	4.44 [113]

Table 1

Mounting Bolt Hole Locations

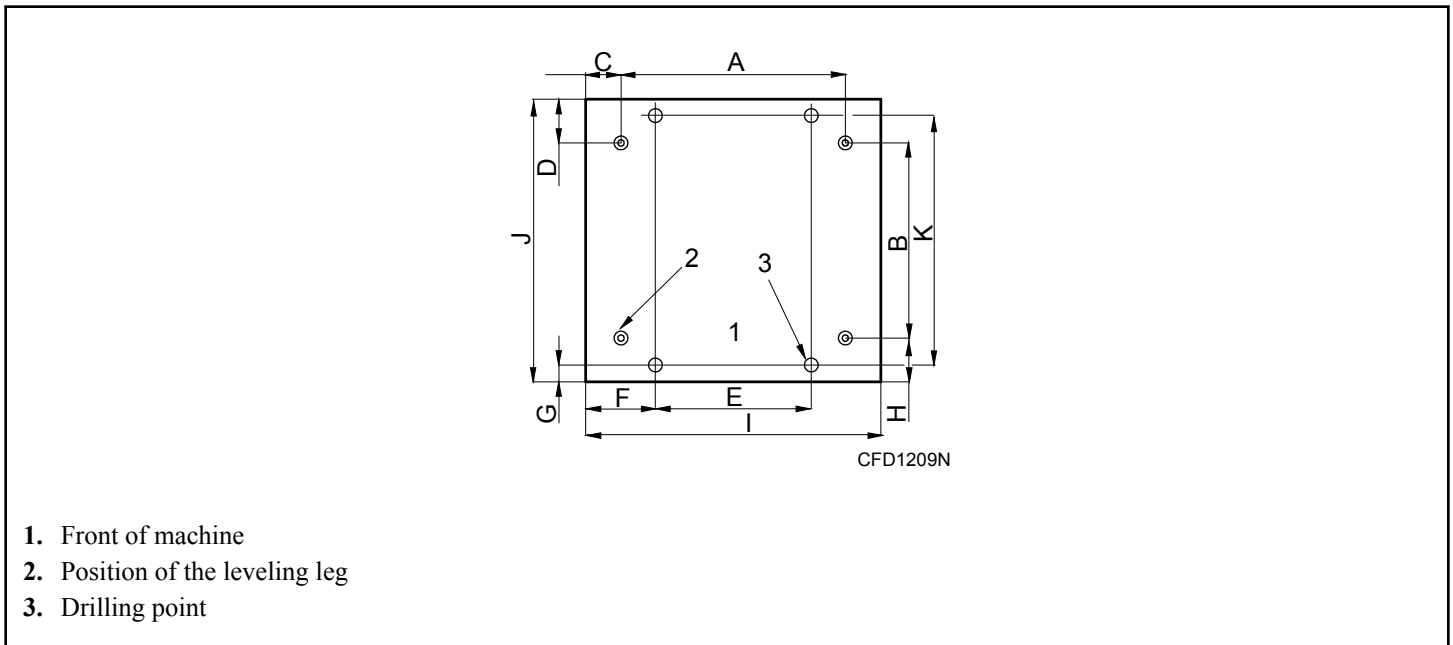

Figure 2

Mounting Bolt Hole Locations, in. [mm]							
Spe cifi- cat- ion	7 kg / 14 lb. / 65 L Models	8 kg / 20 lb. / 80 L Models	11 kg / 25 lb. / 105 L Models	14 kg / 30 lb. / 135 L Models	18 kg / 40 lb. / 180 L Models	24 kg / 55 lb. / 240 L Models	28 kg / 70 lb. / 280 L Models
A	20.86 [530]	20.86 [530]	24.33 [618]	24.33 [618]	30.90 [785]	30.90 [785]	30.90 [785]
B	15.51 [394]	17.48 [444]	17.48 [444]	22.20 [564]	22.04 [560]	27.36 [695]	30.31 [770]
C	3.54 [90]	3.54 [90]	3.48 [88.5]	3.48 [88.5]	3.64 [92.5]	3.64 [92.5]	3.64 [92.5]
D	5.09 [129.5]	5.09 [129.5]	5.09 [129.5]	6.27 [159.5]	8.32 [211.5]	8.32 [211.5]	8.32 [211.5]
E	14.76 [375]	14.76 [375]	17.91 [455]	20.27 [515]	26.37 [670]	26.37 [670]	26.37 [670]
F	6.59 [167.5]	6.59 [167.5]	6.69 [170]	5.51 [140]	5.90 [150]	5.90 [150]	5.90 [150]
G	1.57 [40]	1.57 [40]	1.37 [35]	2.36 [60]	1.96 [50]	1.96 [50]	1.96 [50]
H	4.64 [118]	4.64 [118]	4.64 [118]	4.64 [118]	3.94 [100]	3.94 [100]	3.94 [100]
I	27.95 [710]	27.95 [710]	31.29 [795]	31.29 [795]	38.18 [970]	38.18 [970]	38.18 [970]
J	25.25 [641.5]	27.22 [691.5]	27.22 [691.5]	33.12 [841.5]	34.31 [871.5]	39.62 [1006.5]	42.60 [1082]
K	21.65 [550]	23.62 [600]	24.02 [610]	26.77 [680]	25.98 [660]	31.30 [795]	34.25 [870]

Table 2

Floor Mounting Layout

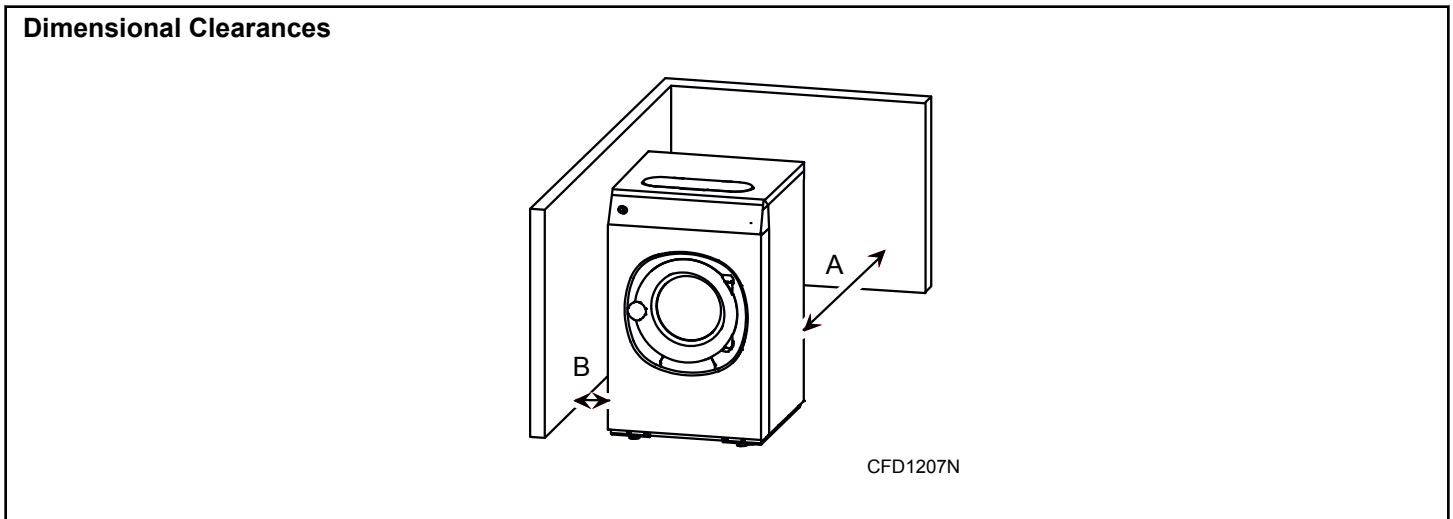

Figure 3

Dimensional Clearances, in. [mm]		
A	Distance to wall (minimum)	20 [500]
B	Distance of machine to side wall or other machine (minimum)	0.79 [20]

Table 3

Installation

Pallet Removal

The machine is delivered bolted onto the transport pallet and packed in shrink-wrap foil or box.

1. Remove packing from machine.
2. Remove front and rear panel.
3. Remove bolts between machine and pallet.
4. Mount front and rear panel.
5. When machine is lifted off pallet, make sure the machine does not come down on the floor with either of the rear corners first. The machine's side panel can be damaged.

NOTE: Two self-adhesive rubber stop-blocks are supplied with the machine. They may be applied as paint protection when opening the door.

6. Mount leveling legs.
7. Level machine with feet of the machine.

	WARNING
<p>It is of utmost importance that the machine is placed level, from side to side as well as front to back. If the machine is not properly leveled, it may result in out-of-balance error without a real out of balance in the drum.</p>	
W913	

8. Recheck the setting of the safety switch, refer to *Every 6 Months*.

Mounting Bolt Installation (If Required)

Machines do not have to be mounted by means of anchoring bolts. If anchoring is necessary, perform the following steps:

1. Drill 2 holes for the anchoring bolts, refer to *Figure 4*. Hole diameter in machine's base is 0.47 in. [12 mm].
2. Place the machine adjacent to the foundation. Do not attempt to move it by pushing on the sides. Always use the bottom of the frame of the washer-extractor to lift and move the whole machine.
3. Place the machine carefully over the two drilled holes.
4. Check that the machine is seated in a perfectly level manner. Adjust leveling legs as needed.

NOTE: After leveling is complete, tighten the nut securely against the machine's base. Refer to *Figure 4*.

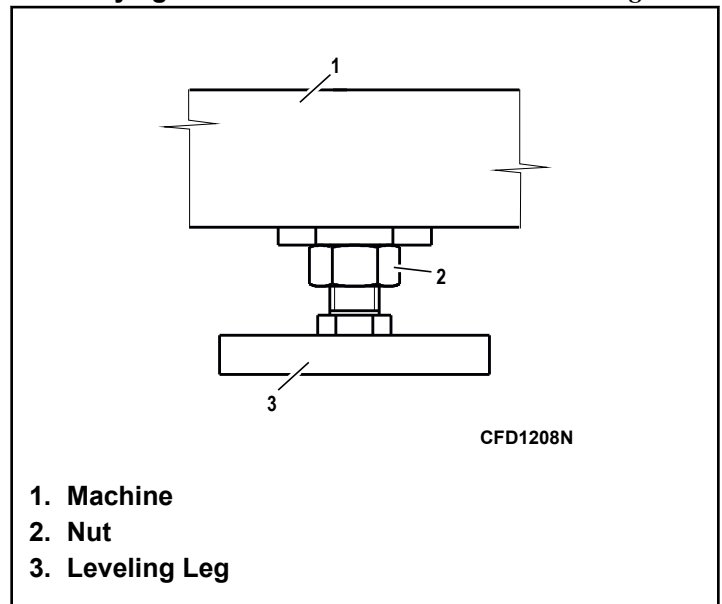

1. Machine
2. Nut
3. Leveling Leg

Figure 4

5. Mount the anchoring bolts in the holes drilled in the floor.
 6. Position washers and locknuts on machinery anchor bolts and finger-tighten to machine base.
- NOTE: If necessary, prop up the machine frame so that not deformation occurs during the tightening of the anchoring bolts.**
7. Remove the shipping braces which secure the moving components of the machine during shipping. Refer to *Shipping Brace Removal*.

Shipping Brace Removal

1. Remove front and rear panel, refer to *Figure 5* .

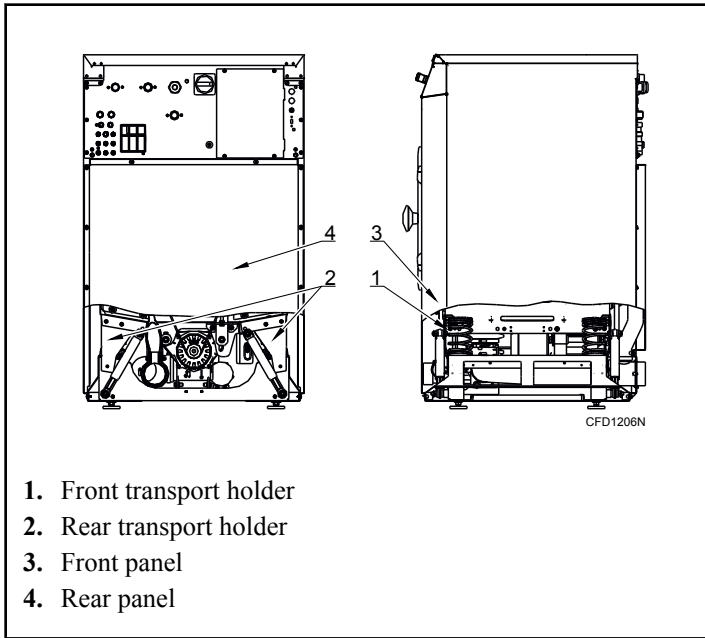

Figure 5

2. Remove both front metal transport holders.
3. Remove both rear transport holders.

IMPORTANT: The machine may not be moved with the shipping braces removed. Save the shipping braces for future use.

Machine Installation

Install the machine close to a floor drain or open drain.

Elevated Base Frame Installation with Existing Floor

The elevated base frame structure must be able to withstand the static and dynamic loads of the machine floor (refer to *General Specifications*), and it must allow the machine to be seated in a perfectly level manner.

Install the machine on a base without adjustable feet.

Weighing System Installation - 18 kg - 28 kg / 40 lb. - 70 lb. / 180 - 280 L Models

1. Lift up the machine.
2. Install two left load sensor supports and two right load sensor supports to the machine frame. Refer to *Figure 6*.

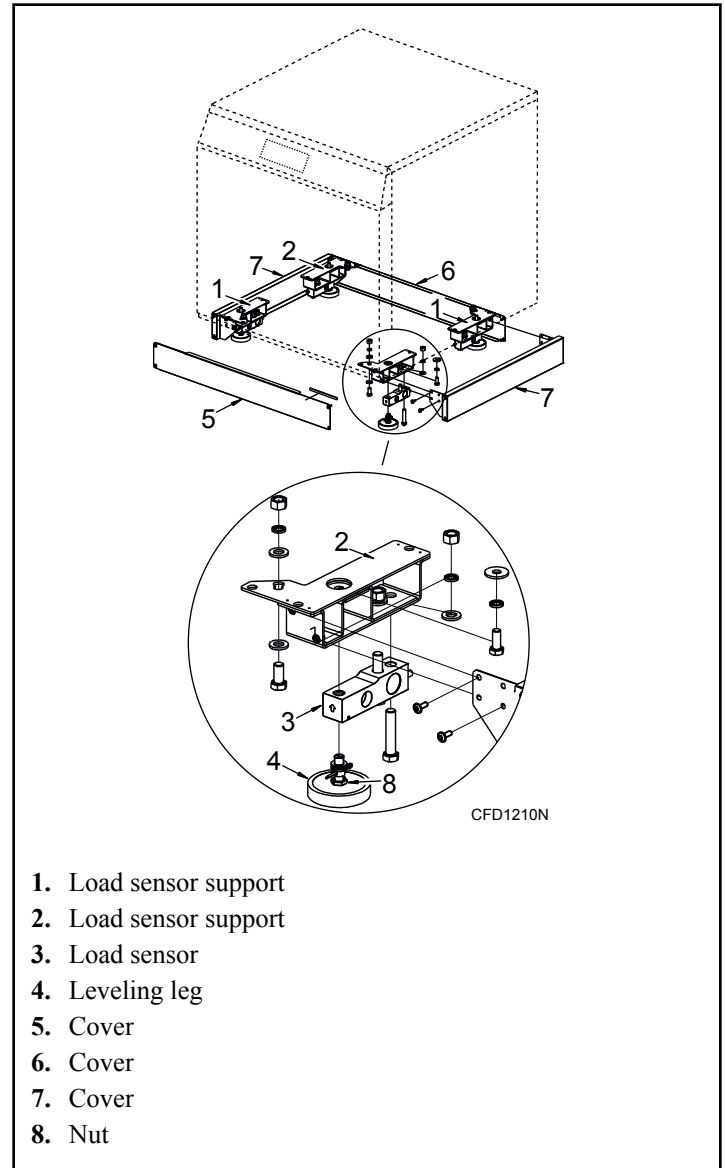

Figure 6

3. Install load sensors with their rubber leveling legs on to the supports.
4. Check that all the supports and load sensors with rubber leveling legs are correctly placed on the machine frame and tightened.
5. Place the machine in the required position.
6. Check that all the rubber leveling legs of the load sensors are stable.
7. Fit the sensor cables into the prepared openings with cable fixtures. Refer to *Figure 7*.

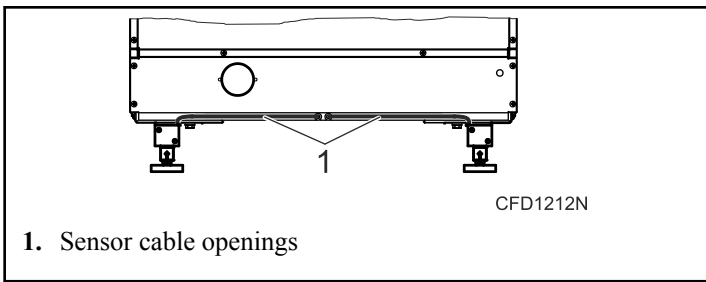

Figure 7

8. Remove the transport safety devices (transport props).
9. Use a water-level to check that the lower frame of machine is positioned totally level.
10. Attach hoses for water supply to the machine.

NOTE: The machine is not anchored into the floor; it stands on the load sensor feet. Take into consideration that the entire machine acts as a measuring gauge. Therefore, anything that you place on to the machine or anything that is in physical contact with it influences the weighing process. Make sure that the water connection, as regards the pressure in the hoses, does not interfere with the weighing. The hoses must no pull or push the machine in any direction or prop it up in any way.

11. Install the covers. Refer to *Figure 6*.
12. Check and, if necessary, adjust the height of the load sensor feet so that an even load distribution among all the load sensors is ensured. Refer to *Figure 8*.

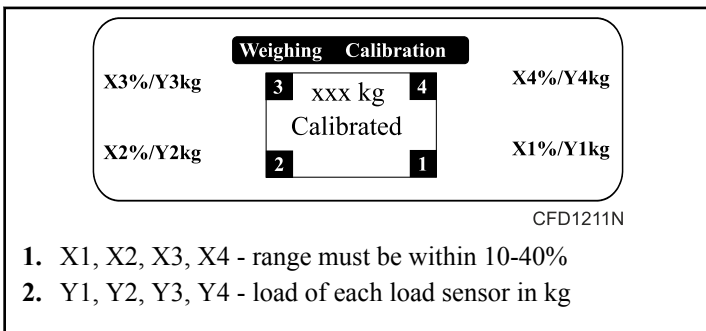

Figure 8

13. If the load sensors are outside of the specified range, it is necessary to adjust the leveling legs of load sensors. Each load sensor leveling leg can be adjusted within the range of 0.2 in. [5 mm].
 - a. Lift up the machine.
 - b. Loosen the nut and turn the level leg in order to achieve the required position.
 - c. Tighten the nut.
 - d. Put the machine down and verify that the load applied to each sensor is within the specified range.

Drain Connection

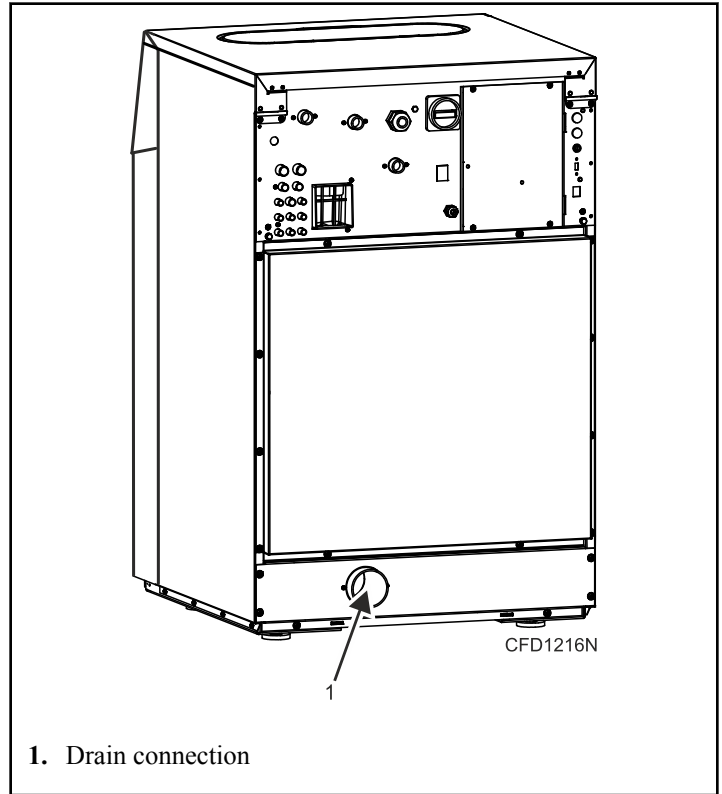

Figure 9

Drain Valve

IMPORTANT: Machine must be installed in accordance with all local codes and ordinances.

All drain systems must be vented to prevent an air lock or siphoning.

Connect a 3 inch [76 mm] pipe or rubber hose to the machine's drain pipe, ensuring a downward flow from the machine. Avoid sharp bends which may prevent proper draining.

The drainage pipe should be located over a floor drain, drainage channel.

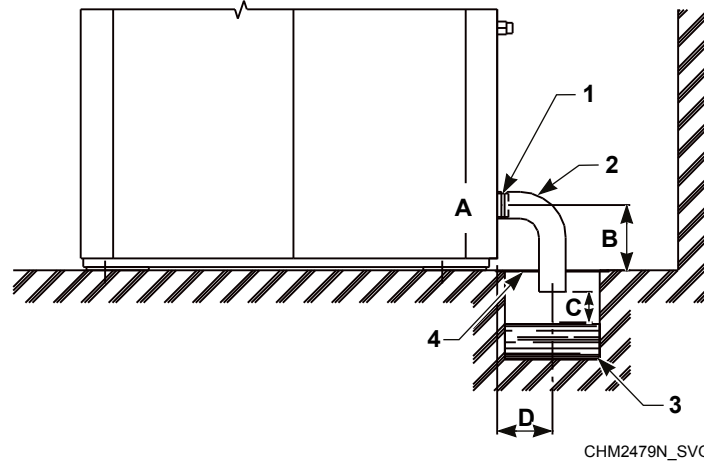

Drainage Pipe Information, in. [mm]

Specification	7 kg / 14 lb. / 65 L Models	8 kg / 20 lb. / 80 L Models	11 kg / 25 lb. / 105 L Models	14 kg / 30 lb. / 135 L Models	18 kg / 40 lb. / 180 L Models	24 kg / 55 lb. / 240 L Models	28 kg / 70 lb. / 280 L Models
A	3 [75]	3 [75]	3 [75]	3 [75]	3 [75]	3 [75]	3 [75]
B	4.17 [106]	4.4 [112]	4.4 [112]	4.4 [112]	5.21 [132.5]	5.21 [132.5]	5.21 [132.5]
C minimum	0.79 [20]	0.79 [20]	0.79 [20]	0.79 [20]	0.79 [20]	0.79 [20]	0.79 [20]
D minimum	3.94 [100]	3.94 [100]	3.94 [100]	3.94 [100]	3.94 [100]	3.94 [100]	3.94 [100]

- 1. Clamp
- 2. Drain elbow 3 in. [76 mm]
- 3. Waste channel
- 4. Waste channel cover

Figure 10

Specification	Model	Requirement
Drain connection number	All	1
Drain connection size, in. [mm]	All	3 [76]

Table 4 continues...

Specification	Model	Requirement
Average flow rate of draining gal/min. [l/min.]	All	55.48 [210]
Drain pump with hose - internal diameter of hose, in [mm]	7 kg - 8 kg / 14 lb. - 20 lb. / 65 L - 80 L	0.75 [19]
Flow rate of drain pump, gal/min. [l/min.]	7 kg - 8 kg / 14 lb. - 20 lb. / 65 L - 80 L	9.51 [36]

Table 4

The main drain channel-pipe must have the capacity to be able to handle the total output of all connected machines. In a drainpipe, a vent must be provided every 65.62 ft. [20 m] to assure the drain pipe will work. If the main drain pipe cannot be sufficiently vented, install a vent per machine. Every time a machine is coupled

on the drainpipe, the diameter of the tube or the width of the waste channel must increase. Refer to *Figure 11*.

The diameters of drain pipe for machines with two drain valves must have dimensions suitable for double the value of water flow.

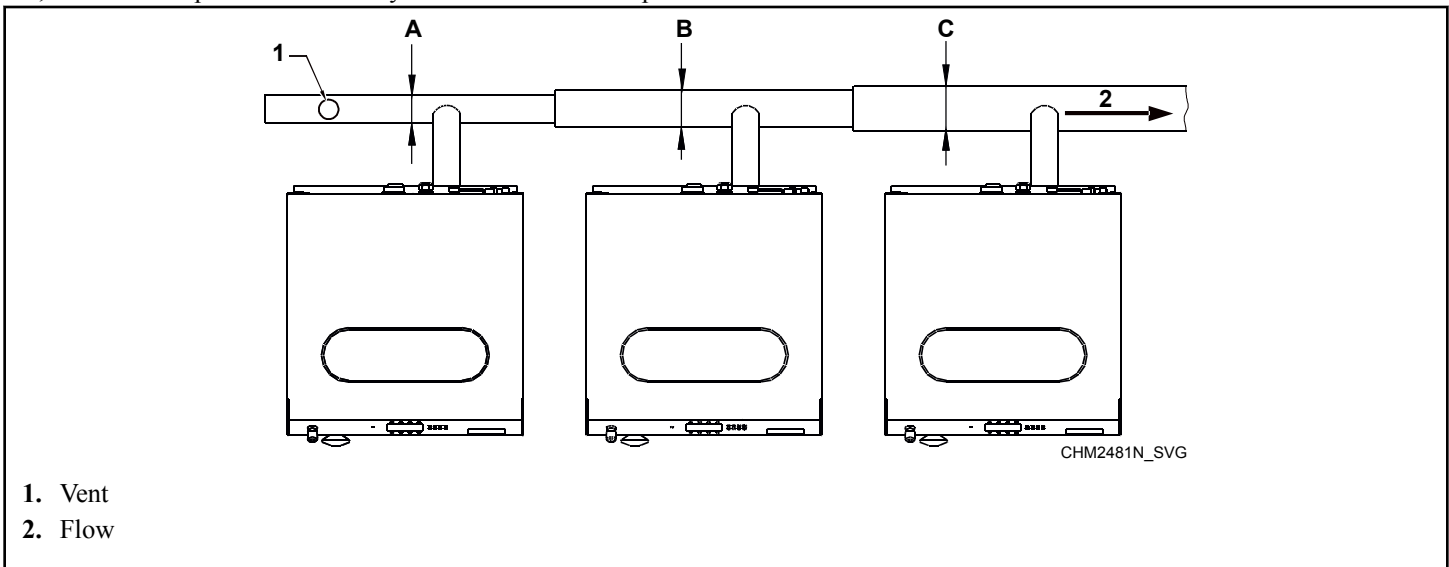

Figure 11

Drain Line Sizing / Minimum Drain ID, in. [mm]		
A - 1 Machine	B - 2 Machines	C - 3 Machines
3 [75]	4 [100]	5 [125]

Table 5

Drain Pump, 7 kg - 8 kg / 14 lb. - 20 lb. / 65 L - 80 L Models

phon effect. In order to achieve good draining, the hose must not bend at a sharp angle. Refer to *Figure 12* .

Connect a flexible hose to a drain pipe so that the hose bend must not be located lower than the water level to provide sufficient si-

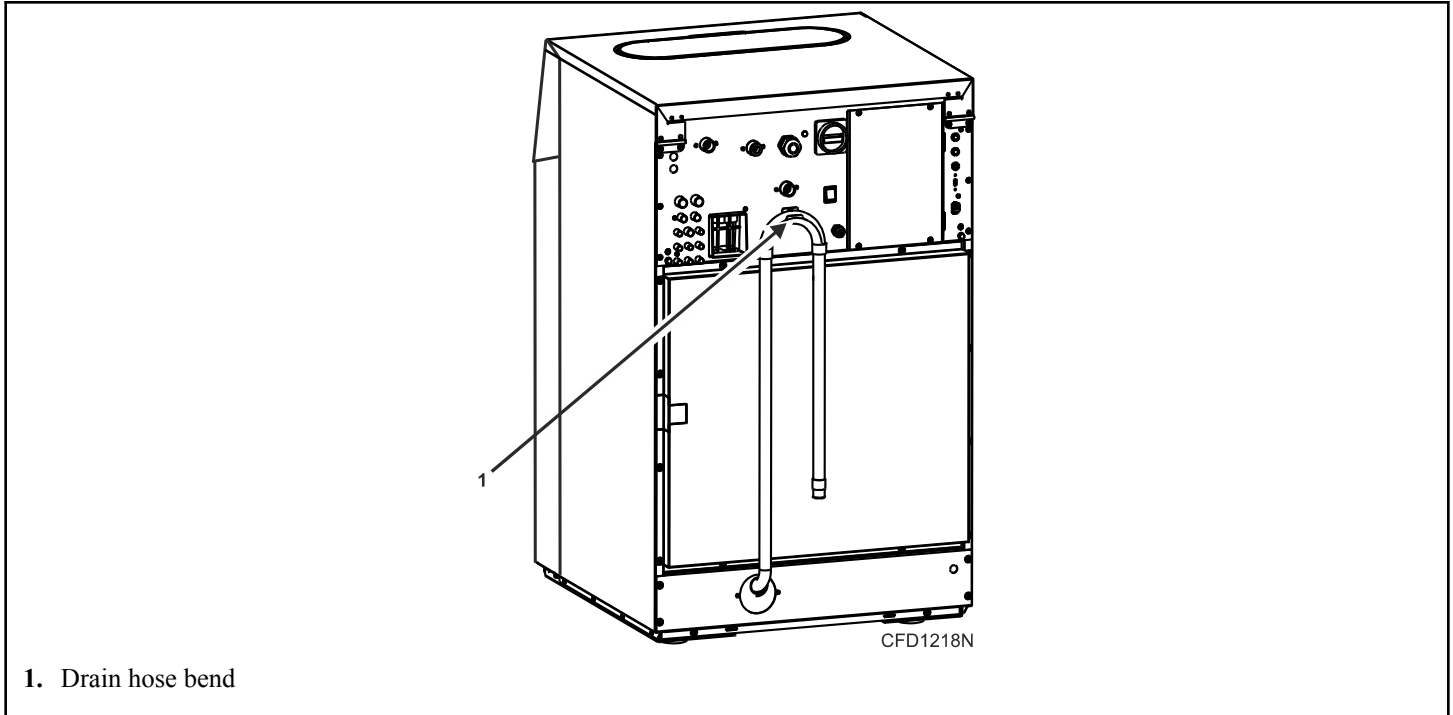



Figure 12

Venting

	WARNING
VAPOURS ESCAPE FROM THE MACHINE THROUGH THE AIR VENT OPENING! DO NOT COVER!	
C238	

Water Connection Requirements

	<h2 style="margin: 0;">WARNING</h2>
<p>To prevent personal injury, avoid contact with inlet water temperatures higher than 125° Fahrenheit [51° Celsius] and hot surfaces.</p>	
<small>W748</small>	

NOTE: North American Models: Water inlet hose with notches should be connected to the water supply faucet, while the side of the water inlet hose without notches should be connected to the water inlet valves. Refer to Figure 13 .

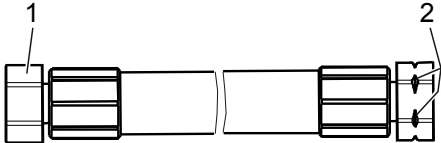

CHM2503N_SVG

1. Water inlet valve connection (hose connection without notch)
2. Water supply faucet connection (hose connection with notch)

Figure 13

NOTE: Models outside of North America: For 7 kg / 14 lb. / 65 L, 8 kg / 20 lb. / 80 L, 11 kg / 25 lb. / 105 L, 14 kg / 30 lb. / 135 L, 18 kg / 40 lb. / 180 L and 24 kg / 55 lb. / 240 L Models, to connect cold water, use a hose with plastic elbow. To connect hot water, use a hose with metal elbow.

Do not re-use water hoses; only use new water hoses.

The appliance has been designed with a built-in "AB" airgap system according to EN1717. Nevertheless, when potable water will be connected to the appliance, an approved double check valve or some other no less effective device providing backflow prevention protection to at least fluid category three shall be fitted at the point of connections between the water supply and the appliance.

All intake connections to the machine are to be fitted with manual shut-off valves and filters, to facilitate installation and servicing.

All water connectors present on the machine must be connected or the wash program will not function correctly. Refer to Table 6 for possible connection options, which will depend on the water types to be connected to the machine, which can be found by checking the machine plates.

2 Water Connection Models

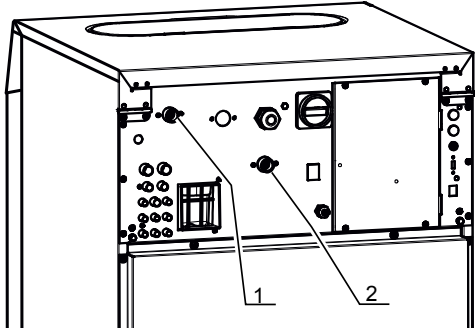

CFD1213N

1. Refer to Table 6 .
2. Refer to Table 6 .

Figure 14

3 Water Connection Models

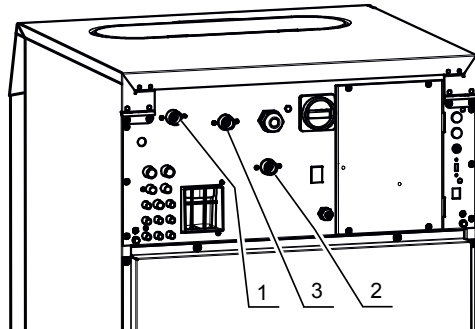

CFD1214N

1. Refer to Table 6 .
2. Refer to Table 6 .
3. Refer to Table 6 .

Figure 15

Water type	Water connection		
	1	2	3
Cold and Hot	Cold	Hot	N/A
Cold soft, Cold hard and Hot	Cold soft	Hot	Cold hard

Table 6

	WARNING
<p>If the water pressure is below the minimum value, the wash result can not be guaranteed for a selected program.</p>	
W914	

The maximum water inlet temperature for vended models is 194°F [90°C] and the recommended maximum water inlet temperature for on-premises models is 150°F [66°C] (standard models) or 140°F [60°C] (WRAS approved models).

Connections should be supplied by a hot and a cold water line of at least the sizes shown in Water Supply Line Sizing. Installation of additional machines will require proportionately larger water lines.

Specification	Model	Requirement
Water inlet connection size, in. BSP	All	3/4
Recommended pressure, PSI [bar]	All	44-73 [3-5]
Inlet flow capacity per inlet, gal/min [l/min.]	7 kg - 24 kg / 14 lb. - 55 lb. / 65 L - 240 L	5.28 [20]
Inlet flow capacity per inlet, gal/min at 15 PSI [l/min. at 1 bar]	18 kg - 28 kg / 40 lb. - 70 lb. / 180 L - 280 L	17.44 [66]
Inlet flow capacity per inlet, gal/min at 116 PSI [l/min. at 8 bar]	18 kg - 28 kg / 40 lb. - 70 lb. / 180 L - 280 L	49.66 [188]

Table 7

Suitable air cushions (risers) should be installed in supply lines to prevent “hammering.”

Alliance Laundry Systems, LLC ranges of front loading commercial clothes washing machines have solenoid valves at the inlets. The water supply to the washing machines is supplied with an AB air gap between the soap tray and the drum. Minimum and maximum working pressure 1 bar and 8 bar. The machines are supplied with approved inlet hoses.

NOTE: This machine has a fluid category 5 backflow prevention device built in between the soap tray and drum.

To comply with WRAS (IRN R150), European standard EN1717, an approved double check valve backflow prevention device with the watermark is provided with the unit and must be fitted at the point of connection(s) between the supply and the fitting.

NOTE: No more than two (2) water connection hoses should be used on WRAS-approved models.

Connections should be supplied by a hot and a cold water line per national and local codes and in accordance with IEC 61770.

To connect water service to a machine with hoses, use the following procedure:

1. Before installing hoses, flush the building’s water system at the machine connection valves for at least two (2) minutes.
2. Check filters in the machine’s inlet hoses for proper fit and cleanliness before connecting.
3. Hang hoses in a large loop; do not allow them to kink.

If additional hose lengths are needed or using hoses other than those supplied by manufacturer, flexible hoses with screen filters are required.



Figure 16

Water Reuse Connection

	WARNING
<p>Disconnect the machine power supply. When the main switch is turned off, the inlet terminals of the machine main switch are still under current.</p>	
W900	

1. Drill out the protective screens of the water reuse inlet using a drill bit of .59 in. [15 mm] diameter. Refer to *Figure 17*.

IMPORTANT: Do not pierce the screens open. It could lead to blockage of the water channel.

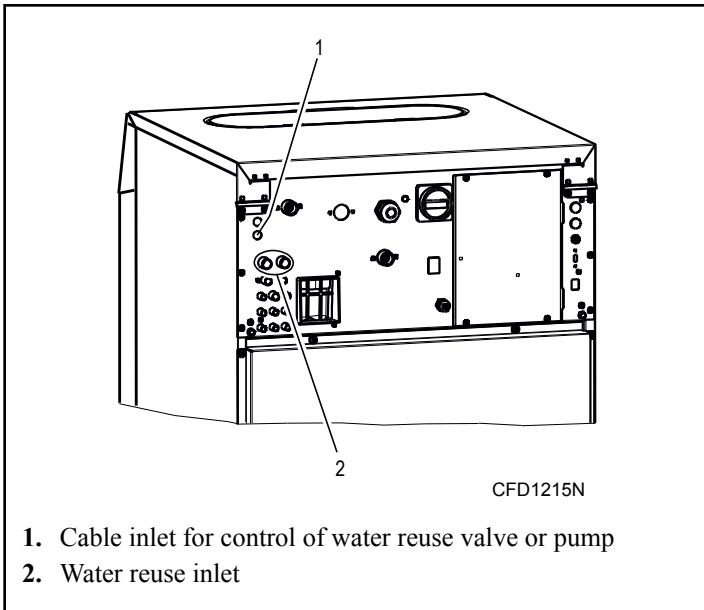

Figure 17

2. Connect the control of your reuse valve or pump onto the conductor of inlet valve I5 or I7 provided by the manufacturer, which will disconnect the valve in question from standard function.

IMPORTANT: The manufacturer waives all responsibility for malfunction of the washing machine if a different valve than the specified I5 or I7 is used as the water recycle valve.

3. Fit a cable bushing into the opening, and pull the cable through the bushing. Refer to *Figure 17*.
4. Connect the coil for control of the recuperated water inlet (the coil is not supplied with the machine), operating voltage 208-240V 50/60 Hz.
5. Secure the cable so that it cannot be pulled out of the machine or inlet valve.

Water Reuse Specifications	
Temperature range, °F [°C]	41 to 194 [5 to 90]
Maximum pressure, PSI [bar]	116 [8]
Connection - outside diameter, in. [mm]	0.75 [19]

The hose and the connector must be resistant to chemical substances which are used for the washing process. It is also possible to use a hose with enhanced performance such as the rubber EPDM hose.

The water reuse system must be fitted with a filter which must be regularly and thoroughly cleaned (based on water quality). This cleaning prevents prolongation of filling up times and malfunction of water valves.

Reused Water Treatment

The reused water must be filtered before entering the water reuse tank. A mechanical filter must be installed which filters off small particles (fluff, buttons, paper, etc.) of sizes 0.0079 in. [0.2 mm] or smaller. The denser the mesh, the better. There must also be a filter installed on the pressure side of the pump. It is also possible to install an additional, chemical filter. The manufacturer advises to consult a specialist in filter systems.

Water Reuse Tank Properties

	WARNING
<p>It is prohibited to heat the water in the reuse tank. This would disturb the temperature balance of the washer and make the remaining chemicals in the recuperated water more active, which would lead to corrosion of the entire installation.</p>	
W901	

The reuse tank must meet the following minimum requirements:

- The tank must be made according to national standards.
- Tank capacity varies depending on multiple factors, so it must be calculated by an authorized engineer. The factors are:
 - The number of washing steps per washer, in which the water will be re-used.
 - The programmable amount of water that will be re-used in a washing step (to find this amount, please refer to the Programming Manual).
 - The number of washers that will deliver water to the reuse tank.
 - The use of recuperated water per washer.

The tank must have an overflow to the sewer. Water from the sewer must not be able to flow back into the reuse tank.

The network of pipes and hoses, the water pump and the reuse tank must be of a non-corroding material. It must be resistant to water and chemicals used for washing.

The tank must be equipped with a system that fills the tank with clean water to a minimum required working level, in case the water level drops below this minimum. If this requirement is not met and an insufficient or no amount of recuperated water is fed into the washer, it will not function properly.

A pump must transport the recuperated water from the tank to the washer. The requirements for the pump depend on the number and type of washers that are connected to the water re-use system. The maximum pump pressure is 116 psi [8 bar].

It is advisable to install a level switch. This level switch must be connected to the microprocessor by means of a potential-free contact. Refer to *Figure 18*.

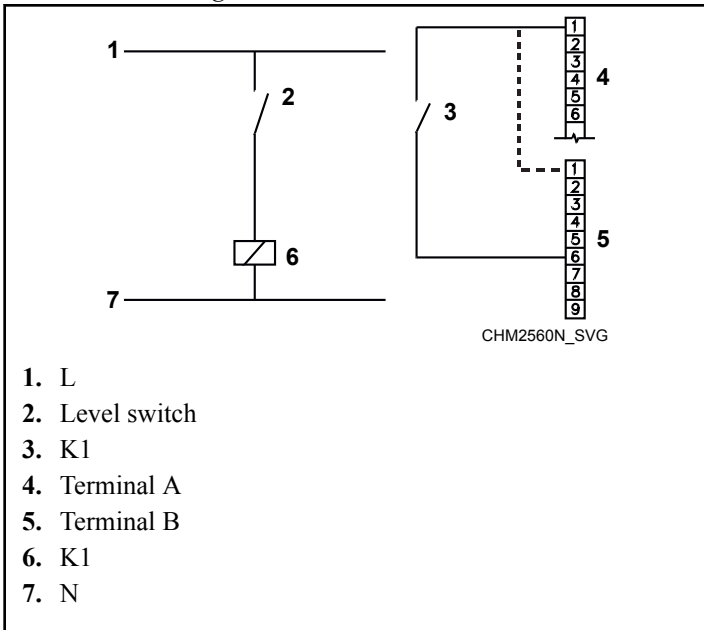

Figure 18

The relay contact K1 has to close when the water level is too low. Terminal B is positioned on the left side, in the lower part of the microprocessor. Terminal A is positioned directly above Terminal B. The microprocessor is positioned inside the washer. If the "Check signal recycle" parameter is set to "yes" in the configuration menu, the timer will send a signal if the water level of the reuse tank is too low.

Electrical Installation Requirements

IMPORTANT: Electrical ratings are subject to change. Refer to serial plate for electrical ratings information specific to your machine.

	DANGER
<p>Electrical shock hazard will result in death or serious injury. Disconnect electric power and wait ten (10) minutes before servicing.</p>	
W911	

	WARNING
<p>Dangerous voltages are present inside the machine. Only qualified personnel should attempt adjustments and troubleshooting. Disconnect power from the machine before removing any cover and guards, and before attempting any service procedures.</p>	
W736	

	WARNING
<p>Hazardous Voltage. Can cause shock, burn or death. Verify that a ground wire from a proven earth ground is connected to the lug near the input power block on this machine.</p>	
W360	

IMPORTANT: If the machine is not equipped with a main switch, supply disconnecting devices need to be provided in the installation for all electrical supplies connected to the machine, in accordance with EN 60204-1 standard, point 5.3.

IMPORTANT: Make sure the supply voltage is always within the limits specified. When you have long distances in the electrical installation, it may be necessary to use bigger cables to reduce the voltage drop.

Models outside of North America:

IMPORTANT: When the machine is connected near a large capacity power supply transformer (500kVA or more, wiring length shorter than 32.81 ft [10 m]) or there is a power capacitor switch-over, a power supply improving reactor must be installed. If you do not install this, the inverter may get damaged. Contact your distributor for more information.

Models outside of North America: For electrical protection, if local regulations allow, there must be installed a residual current device (RCD) and a circuit breaker in the electrical installation of the building (laundry switchboard). Refer to *Figure 19*.

Electrical connections are made at the rear of the machine. The machine must be connected to the proper electrical supply shown on the serial plate on the rear of the machine, using copper conductors only.



WARNING

Grounding: In event of malfunction, breakdown or leakage current, grounding will reduce the risk of electrical shock and serve as a protecting device by providing a path of least resistance of electrical current. Therefore, it is very important and the responsibility of the installer to assure the washer is adequately grounded at installation, following all national and local requirements.

W902

Residual Current Device (RCD) - Models Outside of North America

In some countries, an RCD is known as an Earth Leakage Trip, Ground Fault Circuit Interrupter (GFCI), Appliance Leakage Current Interrupter (ALCI) or Earth (Ground) Leakage Current Breaker.

When locally allowed, an RCD must be installed. In some power network earthing systems, an RCD may not be allowed.

The RCD must have the following specifications:

- Tripping current of 100mA (if not locally available/allowed, use a 30mA trip current, preferably selective type with small time delay set)
- Type B (components inside the machine which make use of DC voltages and require this better performance RCD)
- Maximum of 2 machines installed on each RCD (for 30mA, only 1 machine)

Some washer control circuits are supplied with a separating transformer. Therefore, the RCD may not detect faults in the control circuits (but the fuse(s) on the separating transformer will).

Supply Protection Device

A supply protection device protects the machine and wiring against short circuits. (Glow-wire) fuses or (automatic) circuit breakers may be used as supply protection devices.

Protection must be the "slow" type, which means curve D for circuit breakers.

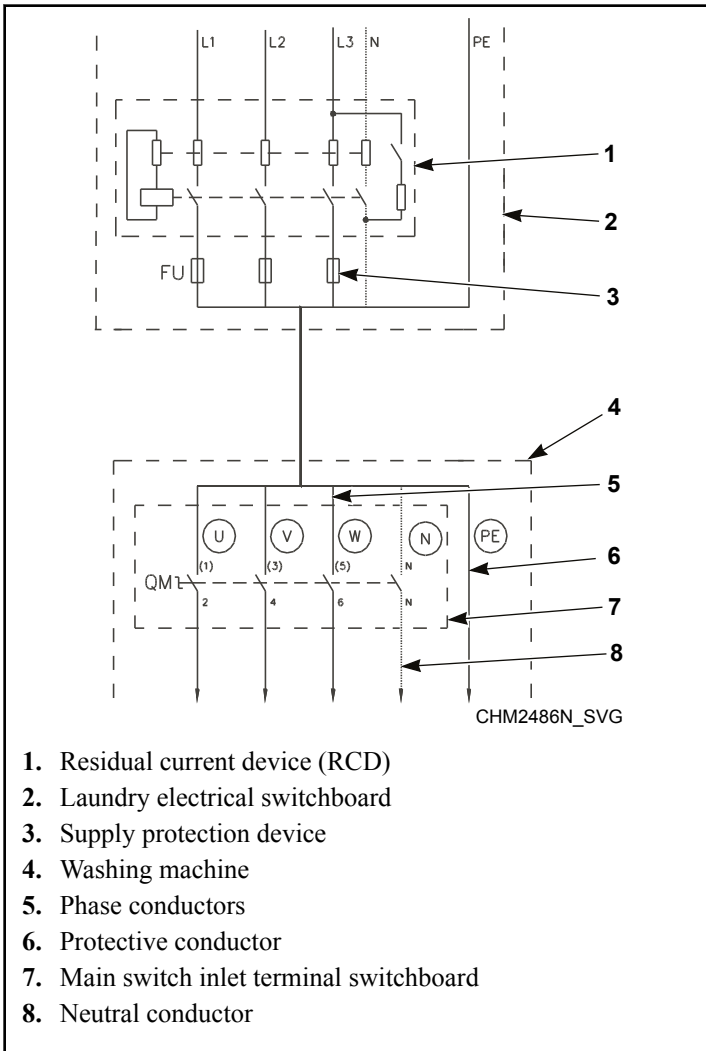

Figure 19

IMPORTANT: Alliance Laundry Systems warranty does not cover components that fail as a result of improper input voltage.

Supply Cable

The supply cable is not delivered with the machine. The supply cable must have the following specifications:

- Conductors with copper cores (For wire size details, refer to *Electrical Specifications - Models Outside of North America* or *Electrical Specifications - North American Models*)

- Stranded conductors (flexible wiring) that can withstand vibration from machine
- For crossection size, refer to *Table 8 Determining AWG Sizes*
- Route the supply cable as short as possible, directly from the supply protection device to the washer without branching off
- Do not use a plug or extensions cords (the machine is intended to be permanently connected to the electrical network)

Power supply protection device nominal current (US)		Min. phase conductor section, AWG [mm ²]	Min. protection conductor section, AWG [mm ²]
Automatic circuit breakers	Fuses		
16A (15A)	10A (10A)	15 [1.5]	15 [1.5]
20A (20A)	16A (15A)	13 [2.5]	13 [2.5]
25A (-)	20A (20A)	11 [4]	11 [4]
40A (40A)	32A (30A)	9 [6]	9 [6]
63A (-)	50A (50A)	7 [10]	7 [10]
80A	63A	5 [16]	5 [16]
100A	80A	3 [25]	5 [16]
125A	100A	2 [35]	3 [25]

Table 8 Determining AWG Sizes

To connect the supply cable, the following steps must be performed:

1. Insert cable through opening on rear panel. Insure a strain relief is used so the supply cable can not move.
2. Strip the conductor ends. Refer to *Figure 20*. The protection conductor must be longer so it can be routed to the machine without tension.

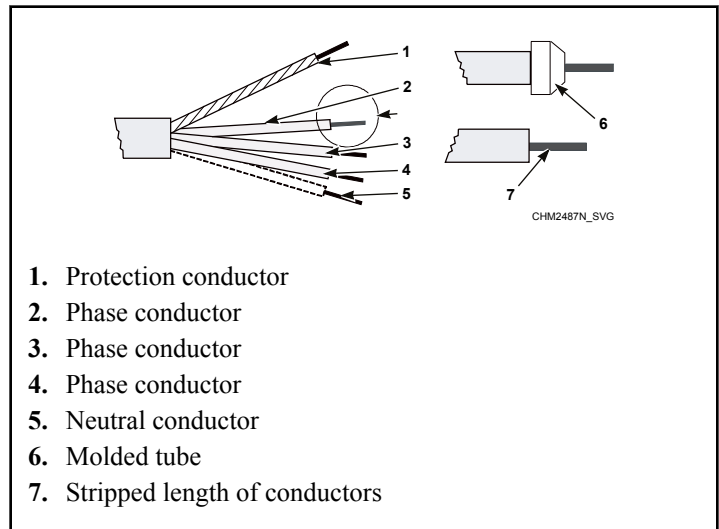

Figure 20

3. With stranded conductors, use wire end tubes with an insulated sleeve (6) for L1/U, (L2/V), (L3/W), (N) conductors. Make sure there is no accidental contact, since the supply cable stays under voltage even when the main switch is off.
4. Crimp a ring terminal to the protection conductor so it stays fixed to the PE terminal.

- Connect the supply cable conductors to the incoming terminals (main switch [1]), marked with L1/U, (L2/V), (L3/W), (N) and the terminal marked with PE. Refer to *Figure 21* or *Figure 22*.

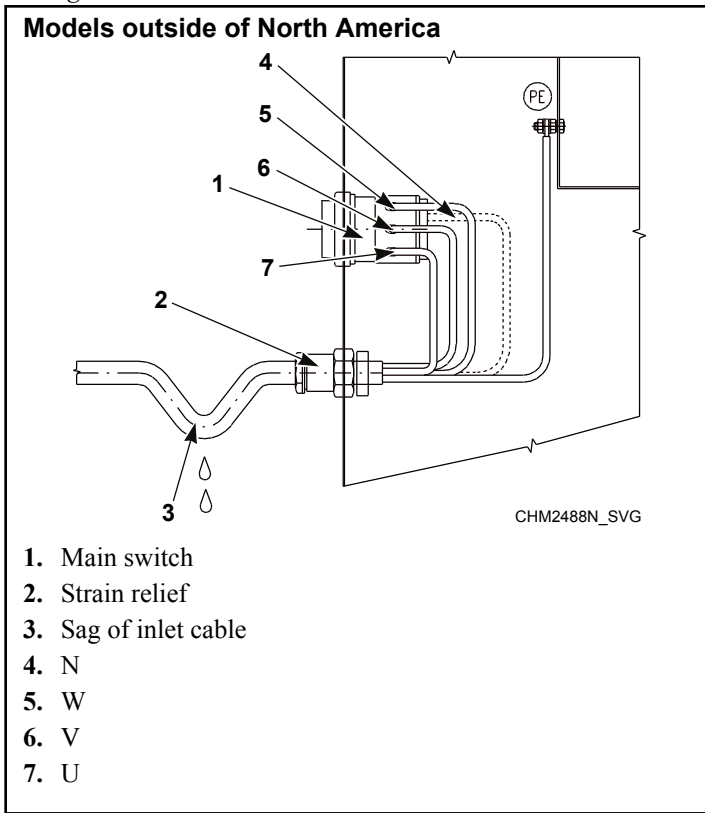

Figure 21

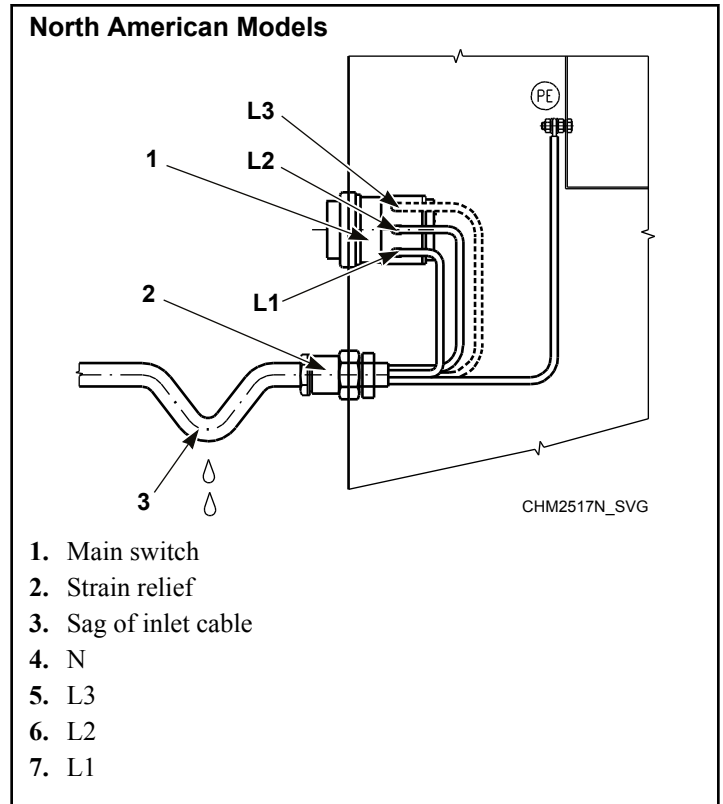

Figure 22

Provide a sag in the cable, in front of the strain relief. This will prevent condensed water from dripping into the machine. Refer to *Figure 21* or *Figure 22*.

Machine Protective Earth Connection and Equipotential Bonding

If there are other washers or appliances with exposed conductive parts, which can touch simultaneously, make sure to make equipotential bonding between all these appliances. The external protective terminal for this purpose is located on the rear panel of the machine frame. The minimum protection conductor's cross section depends on the supply cable cross section (refer to *Table 8 Determining AWG Sizes*). However, for the protection purposes, with the supply cable cross section of a min. 4 mm², select a larger conductor section, i.e., 6 mm².

Input Power Conditioning

The drive is suitable for direct connection to input power within the rated voltage of the drive. Listed in *Input Power Condition* are certain input power conditions which may cause component damage or reduction in product life. If any of the conditions exist,

install one of the devices listed under the Possible Corrective Action(s).

IMPORTANT: Only one device per branch circuit is required. It should be mounted closest to the branch and sized to handle the total current of the branch circuit.

Input Power Condition	Possible Corrective Action(s)
Low Line impedance (less than 1% line reactance)	<ul style="list-style-type: none"> • Install Line Reactor • Isolation Transformer
Greater than 120 kVA supply transformer	
Line has power factor correction capacitors	<ul style="list-style-type: none"> • Install Line Reactor • Isolation Transformer
Line has frequent power interruptions	
Line has intermittent noise spikes in excess of 6000V (lightning)	
Phase to ground voltage exceeds 125% of normal line to line voltage	<ul style="list-style-type: none"> • Remove MOV jumper to ground • Install Isolation Transformer with grounded secondary (if necessary)
Ungrounded distribution system	
240V open delta configuration (stinger leg)*	<ul style="list-style-type: none"> • Install Line Reactor
<p>* For drives applied on an open delta with a middle phase grounded neutral system, the phase opposite the phase that is tapped in the middle to the neutral or earth is referred to as the “stinger leg,” “high leg,” “red leg,” etc. This leg should be identified throughout the system with red or orange tape on the wire at each connection point. The stinger leg should be connected to the center Phase B on the reactor.</p>	

Table 9

Input Voltage Requirements

For voltages above or below listed specifications, contact your power company or local electrician.

If machine is intended for four-wire service, a neutral leg must be provided by power company.

If a delta supply system is used on a four-wire model, connect high leg to L3.

IMPORTANT: Improper connections will result in equipment damage and will void warranty.

	DANGER
<p>Electrical shock hazard will result in death or serious injury. Disconnect electric power and wait five (5) minutes before servicing.</p>	
W810	

	DANGER
<p>Hazardous Rotation Speed. Will cause serious injury when controlling AC inverter drive with a parameter unit, safety features are bypassed allowing basket to rotate at high speeds with the door open. Place large sign on front of machine to warn people of imminent danger.</p>	
W361	

Circuit Breakers and Quick Disconnects

Single-phase machines require a single-phase inverse-time circuit breaker. Three-phase machines require a separate, three-phase inverse-time circuit breaker to prevent damage to the motor by disconnecting all legs if one should be lost accidentally. Refer to section for model-specific circuit breaker requirements.

IMPORTANT: All quick disconnects should comply with the specifications. DO NOT use fuses instead of circuit breakers.

Connection Specifications

IMPORTANT: Connection must be made by a qualified electrician using wiring diagram provided with machine, or according to accepted European Union standards.

Connect machine to an individual branch circuit not shared with lighting or other equipment. Shield connection in a liquid-tight or approved flexible conduit. Copper conductors of correct size must be installed in accordance with National Electric Code (NEC) or other applicable codes.

Use wire sizes indicated in the Electrical Specifications chart for runs up to 50 feet [15 m]. Use next larger size for runs of 50 to 100 feet [15 to 30 m]. Use two (2) sizes larger for runs greater than 100 feet [30 m].

Single-Phase Connections

Single Phase Connection - North American Models

Connect the electrical service's wires to the machine's electrical connection terminal as shown.

Electrical Service Wire	Machine's Electrical Connection Terminal
L1	L1
L2	L2
PE	PE (Ground)

Table 10

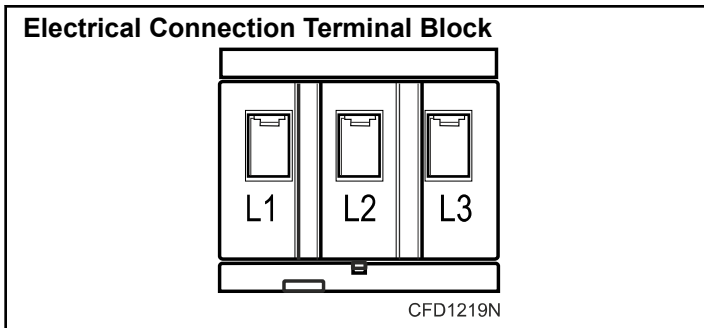

Figure 23

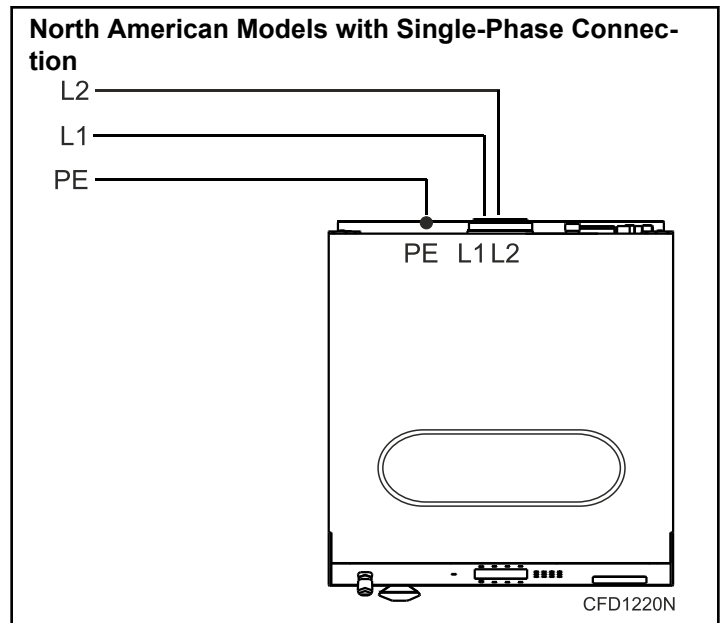

Figure 24

Single Phase Connection - Models outside of North America

Connect the electrical service's wires to the machine's electrical connection terminal as shown.

Electrical Service Wire	Machine's Electrical Connection Terminal
U	U
Neutral	N
PE	PE (Ground)

Table 11

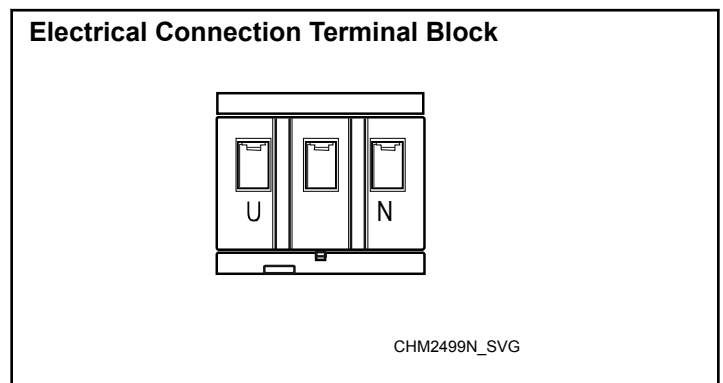

Figure 25

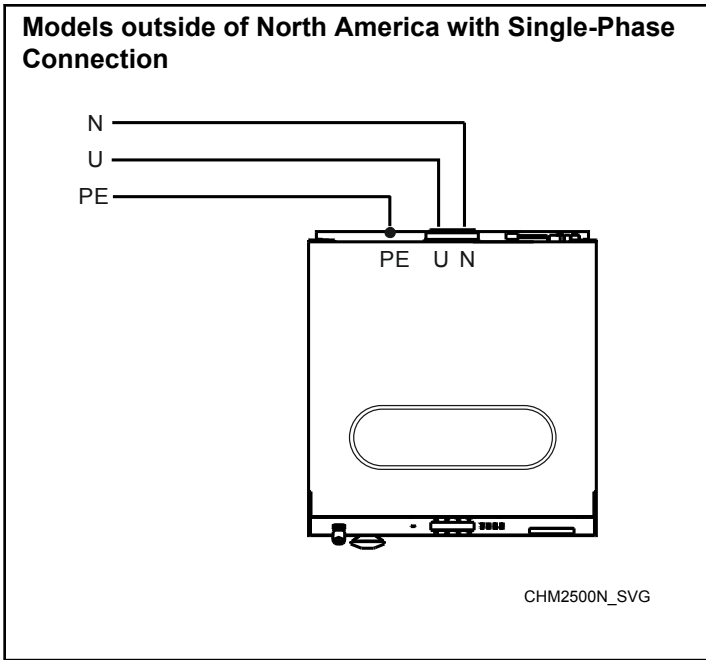

Figure 26

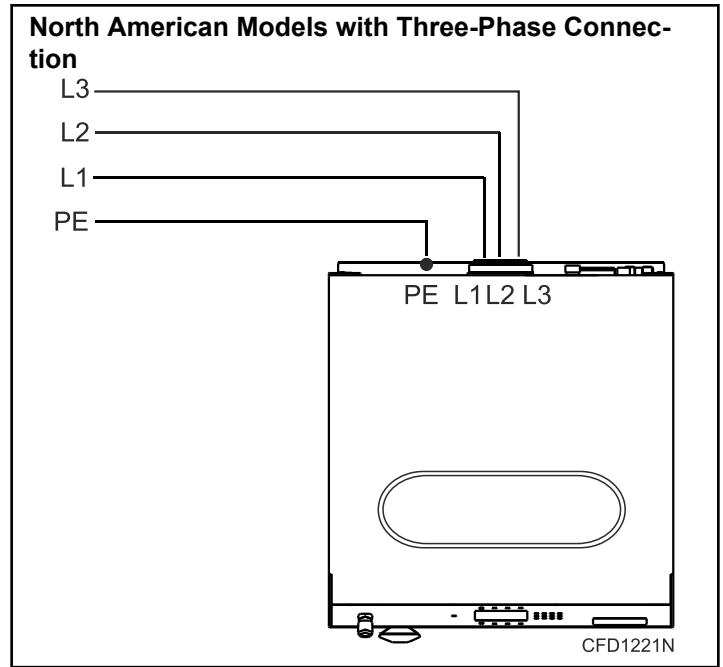

Figure 27

Three-Phase Connections

Three Phase Connection - North American Models

Connect the electrical service's wires to the machine's electrical connection terminal as shown.

Electrical Service Wire	Machine's Electrical Connection Terminal
L1	L1
L2	L2
L3	L3
PE	PE (Ground)

Table 12

Three Phase Connection - Models Outside of North America

Connect the electrical service's wires to the machine's electrical connection terminal as shown.

Electrical Service Wire	Machine's Electrical Connection Terminal
U	U
V	V
W	W
PE	PE (Ground)

Table 13

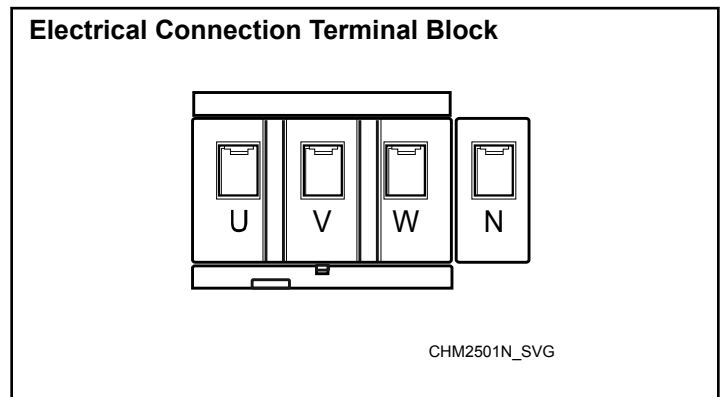

Figure 28

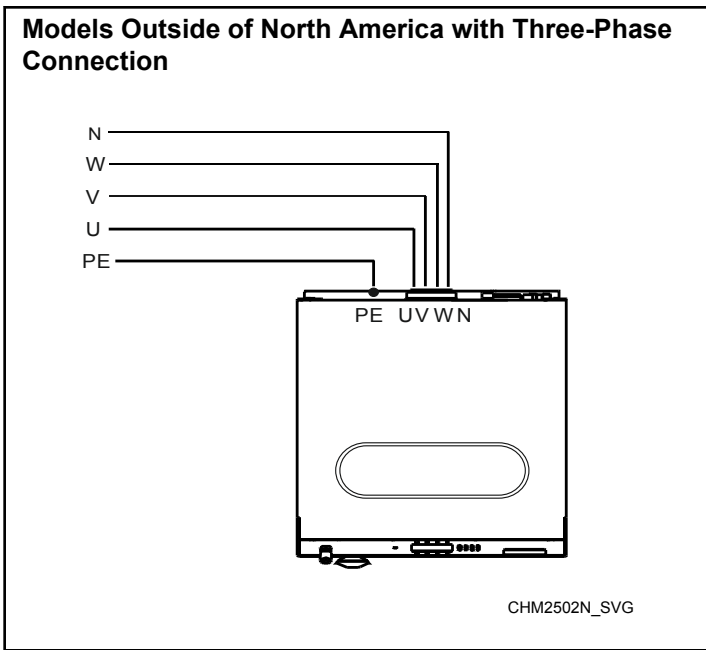

Figure 29

Phase Adder

Machines can be converted for lower voltage operation and/or 50 Hz operation. Refer to conversion label by serial plate for details.

IMPORTANT: Do not use a phase adder on any machine.

Thermal Overload Protector

For models with inverter drives, the inverter drive provides overload protection for the drive motor.

Electrical Specifications - Models Outside of North America

7 kg / 14 lb. / 65 L Models

Voltage	Cycle	Phase	Wire	Total power (kW)	Hot and Cold Water Inlet Valves Full Load Amps	Electric Heat Full Load Amps (Electric Heating kW)	Fuse (A)
200-240	50-60	1	2 (L1, L2, or L1, N)	0.85	6.6	N/A	10
200-240	50-60	1	2 (L1, L2 or L1, N)	3.6	N/A	17.9 (3)	20
200-240	50-60	1	2 (L1, L2, or L1, N)	5.2	N/A	24.9 (4.6)	32
200-240	50-60	3	3 (L1, L2, L3)	6.7	N/A	20 (6)	25
200-240	50-60	3	3 (L1, L2, L3)	9.7	N/A	27.5 (9)	32
380-415 + N	50-60	3	4 (L1, L2, L3, N)	6.7	N/A	13.5 (6)	16
380-415 + N	50-60	3	4 (L1, L2, L3, N)	9.7	N/A	18 (9)	20

Table 14 continues...

Voltage	Cycle	Phase	Wire	Total power (kW)	Hot and Cold Water Inlet Valves Full Load Amps	Electric Heat Full Load Amps (Electric Heating kW)	Fuse (A)
380-415	50-60	3	3 (L1, L2, L3)	0.85	2.4	N/A	10
440-480	50-60	3	3 (L1, L2, L3)	0.85	2.4	N/A	10
380-415	50-60	3	3 (L1, L2, L3)	6.7	N/A	9.9 (6)	16
380-415	50-60	3	3 (L1, L2, L3)	9.7	N/A	15.3 (9)	20
440-480	50-60	3	3 (L1, L2, L3)	9.7	N/A	13.8 (9)	16

Table 14

8 kg / 20 lb. / 80 L Models

Voltage	Cycle	Phase	Wire	Total power (kW)	Hot and Cold Water Inlet Valves Full Load Amps	Electric Heat Full Load Amps (Electric Heating kW)	Fuse (A)
200-240	50-60	1	2 (L1, L2, or L1, N)	0.85	6.7	N/A	10
200-240	50-60	1	2 (L1, L2 or L1, N)	3.6	N/A	18 (3)	20
200-240	50-60	1	2 (L1, L2, or L1, N)	5.2	N/A	25.1 (4.6)	32
200-240	50-60	3	3 (L1, L2, L3)	6.7	N/A	20.2 (6)	25
200-240	50-60	3	3 (L1, L2, L3)	9.7	N/A	27.9 (9)	32
380-415 + N	50-60	3	4 (L1, L2, L3, N)	6.7	N/A	13.7 (6)	16
380-415 + N	50-60	3	4 (L1, L2, L3, N)	9.7	N/A	18.2 (9)	20
380-415	50-60	3	3 (L1, L2, L3)	0.85	2.5	N/A	10
440-480	50-60	3	3 (L1, L2, L3)	0.85	2.5	N/A	10
380-415	50-60	3	3 (L1, L2, L3)	6.7	N/A	10 (6)	16
380-415	50-60	3	3 (L1, L2, L3)	9.7	N/A	15.4 (9)	20
440-480	50-60	3	3 (L1, L2, L3)	9.7	N/A	13.9 (9)	16

Table 15

11 kg / 25 lb. / 105 L Models

Voltage	Cycle	Phase	Wire	Total power (kW)	Hot and Cold Water Inlet Valves Full Load Amps	Electric Heat Full Load Amps (Electric Heating kW)	Fuse (A)
200-240	50-60	1	2 (L1, L2, or L1, N)	1.2	9.8	N/A	16
200-240	50-60	1	2 (L1, L2 or L1, N)	3.8	N/A	18.5 (3)	25
200-240	50-60	1	2 (L1, L2, or L1, N)	5.4	N/A	25.5 (4.6)	32
200-240	50-60	3	3 (L1, L2, L3)	6.8	N/A	20.5 (6)	25
200-240	50-60	3	3 (L1, L2, L3)	9.8	N/A	28.1 (9)	32
200-240	50-60	3	3 (L1, L2, L3)	12.8	N/A	35.6 (12)	40
380-415 + N	50-60	3	4 (L1, L2, L3, N)	6.8	N/A	14.1 (6)	16
380-415 + N	50-60	3	4 (L1, L2, L3, N)	9.8	N/A	18.5 (9)	20
380-415 + N	50-60	3	4 (L1, L2, L3, N)	12.8	N/A	22.8 (12)	25
380-415	50-60	3	3 (L1, L2, L3)	1.2	3.2	N/A	10
440-480	50-60	3	3 (L1, L2, L3)	1.2	3.2	N/A	10
380-415	50-60	3	3 (L1, L2, L3)	6.8	N/A	10.1 (6)	16
380-415	50-60	3	3 (L1, L2, L3)	9.8	N/A	15.5 (9)	16
440-480	50-60	3	3 (L1, L2, L3)	9.8	N/A	14 (9)	16
380-415	50-60	3	3 (L1, L2, L3)	12.8	N/A	19.9 (12)	25

Table 16 *continues...*

Voltage	Cycle	Phase	Wire	Total power (kW)	Hot and Cold Water Inlet Valves Full Load Amps	Electric Heat Full Load Amps (Electric Heating kW)	Fuse (A)
440-480	50-60	3	3 (L1, L2, L3)	12.8	N/A	18.2 (12)	25

Table 16

14 kg / 30 lb. / 135 L Models

Voltage	Cycle	Phase	Wire	Total power (kW)	Hot and Cold Water Inlet Valves Full Load Amps	Electric Heat Full Load Amps (Electric Heating kW)	Fuse (A)
200-240	50-60	1	2 (L1, L2, or L1, N)	1.6	10.1	N/A	16
200-240	50-60	1	2 (L1, L2, or L1, N)	5.7	N/A	27 (4.6)	32
200-240	50-60	3	3 (L1, L2, L3)	10.1	N/A	29.6 (9)	32
200-240	50-60	3	3 (L1, L2, L3)	13.1	N/A	37.2 (12)	40
380-415 + N	50-60	3	4 (L1, L2, L3, N)	10.1	N/A	18 (9)	20
380-415 + N	50-60	3	4 (L1, L2, L3, N)	13.1	N/A	22.6 (12)	25
380-415	50-60	3	3 (L1, L2, L3)	1.6	3.6	N/A	10
440-480	50-60	3	3 (L1, L2, L3)	1.6	3.6	N/A	10
380-415	50-60	3	3 (L1, L2, L3)	10.1	N/A	16 (9)	20
440-480	50-60	3	3 (L1, L2, L3)	10.1	N/A	14.8 (9)	16
380-415	50-60	3	3 (L1, L2, L3)	13.1	N/A	19.9 (12)	20
440-480	50-60	3	3 (L1, L2, L3)	13.1	N/A	18.7 (12)	25

Table 17

18 kg / 40 lb. / 180 L Models

Voltage	Cycle	Phase	Wire	Total power (kW)	Hot and Cold Water Inlet Valves Full Load Amps	Electric Heat Full Load Amps (Electric Heating kW)	Fuse (A)
200-240	50-60	1	2 (L1, L2, or L1, N)	2.3	14.2	N/A	20
200-240	50-60	3	3 (L1, L2, L3)	13.5	N/A	37.9 (12)	40
200-240	50-60	3	3 (L1, L2, L3)	19.5	N/A	53.3 (18)	63
380-415 + N	50-60	3	4 (L1, L2, L3, N)	13.5	N/A	23.1 (12)	25
380-415 + N	50-60	3	4 (L1, L2, L3, N)	19.5	N/A	31.9 (18)	32
380-415	50-60	3	3 (L1, L2, L3)	2.3	5.2	N/A	10
440-480	50-60	3	3 (L1, L2, L3)	2.3	5.2	N/A	10
380-415	50-60	3	3 (L1, L2, L3)	13.5	N/A	20.9 (12)	25
440-480	50-60	3	3 (L1, L2, L3)	13.5	N/A	19.7 (12)	25
380-415	50-60	3	3 (L1, L2, L3)	19.5	N/A	30.5 (18)	32
440-480	50-60	3	3 (L1, L2, L3)	19.5	N/A	27.2 (18)	32

Table 18

24 kg / 55 lb. / 240 L Models

Voltage	Cycle	Phase	Wire	Total power (kW)	Hot and Cold Water Inlet Valves Full Load Amps	Electric Heat Full Load Amps (Electric Heating kW)	Fuse (A)
200-240	50-60	1	2 (L1, L2, or L1, N)	3.1	15	N/A	20
200-240	50-60	3	3 (L1, L2, L3)	20	N/A	54.3 (18)	63
380-415 + N	50-60	3	4 (L1, L2, L3, N)	20	N/A	31.9 (18)	32
380-415	50-60	3	3 (L1, L2, L3)	3.1	7.1	N/A	10
440-480	50-60	3	3 (L1, L2, L3)	3.1	7.1	N/A	10
380-415	50-60	3	3 (L1, L2, L3)	20	N/A	31.5 (18)	32
440-480	50-60	3	3 (L1, L2, L3)	20	N/A	28.2 (18)	32

Table 19

28 kg / 70 lb. / 280 L Models

Voltage	Cycle	Phase	Wire	Total power (kW)	Hot and Cold Water Inlet Valves Full Load Amps	Electric Heat Full Load Amps (Electric Heating kW)	Fuse (A)
200-240	50-60	1	2 (L1, L2, or L1, N)	3.1	16	N/A	20
200-240	50-60	3	3 (L1, L2, L3)	23.9	N/A	64 (21.9)	80
380-415 + N	50-60	3	4 (L1, L2, L3, N)	23.9	N/A	40.5 (21.9)	50
380-415	50-60	3	3 (L1, L2, L3)	3.1	7.2	N/A	10
440-480	50-60	3	3 (L1, L2, L3)	3.1	7.2	N/A	10
380-415	50-60	3	3 (L1, L2, L3)	23.9	N/A	37 (21.9)	40
440-480	50-60	3	3 (L1, L2, L3)	23.9	N/A	34 (21.9)	40

Table 20

Electrical Specifications - North American Models**8 kg / 20 lb. / 80 L Models**

Code	Voltage	Cycle	Phase	Wire	Full Load Amps	Circuit Breaker CSA	AWG (mm ²)
X	200-240	60	1/3	2 (L1, L2 or L1, N)	6.7	10	14 (2.5)

Table 21

11 kg / 25 lb. / 105 L Models

Code	Voltage	Cycle	Phase	Wire	Full Load Amps	Circuit Breaker CSA	AWG (mm ²)
X	200-240	60	1/3	2 (L1, L2 or L1, N)	9.8	15	14 (2.5)

Table 22

14 kg / 30 lb. / 135 L Models

Code	Voltage	Cycle	Phase	Wire	Full Load Amps	Circuit Breaker CSA	AWG (mm ²)
X	200-240	60	1/3	2 (L1, L2 or L1, N)	10.1	15	14 (2.5)

Table 23

18 kg / 40 lb. / 180 L Models

Code	Voltage	Cycle	Phase	Wire	Full Load Amps	Circuit Breaker CSA	AWG (mm ²)
X	200-240	60	1/3	2 (L1, L2 or L1, N)	14.2	20	12 (4)

Table 24

24 kg / 55 lb. / 240 L Models

Code	Voltage	Cycle	Phase	Wire	Full Load Amps	Circuit Breaker CSA	AWG (mm ²)
X	200-240	60	1/3	2 (L1, L2 or L1, N)	15	20	12 (4)
N	440-480	60	3	3 (L1, L2, L3)	7.1	10	14 (2.5)

Table 25

28 kg / 70 lb. / 280 L Models

Code	Voltage	Cycle	Phase	Wire	Full Load Amps	Circuit Breaker CSA	AWG (mm ²)
X	200-240	60	1/3	2 (L1, L2 or L1, N)	16	20	14 (2.5)
N	440-480	60	3	3 (L1, L2, L3)	7.2	10	14 (2.5)

Table 26

Steam Requirements (Steam Heat Option Only)

	WARNING
<p>Hot Surfaces. Will cause severe burns. Turn steam off and allow steam pipes, connections and components to cool before touching.</p>	
W505	

For machines equipped with optional steam heat, install piping in accordance with approved commercial steam practices. Steam requirements are shown in *Table 27*.

Specification	Requirement
Steam inlet connection size, in. BSP	1/2"
Steam pressure, PSI [bar]	15-116 [1-8]

Table 27

IMPORTANT: It is necessary to insert a filter with permeability up to 0.0118 in. [300 µm] in front of the steam valve. Dirt larger than 0.0118 in. [300 µm] may damage the steam valve and cause leaks.

IMPORTANT: Failure to install the customer supplied steam filter may void the warranty.

Use an inlet steam pressure hose only adapted to the steam valve with appropriate seal suitable for the applied working pressure.

Steam Valve Installation

1. Remove the rear cover.
2. Fit the bracket with the steam valve and filter onto the rear part of machine.

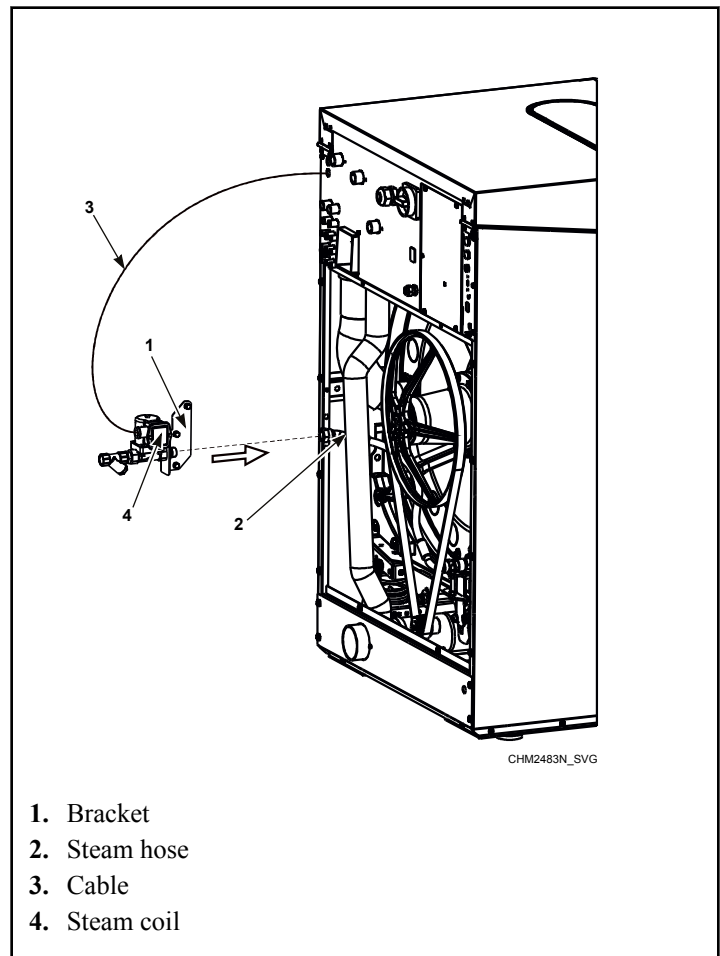



Figure 30

3. Connect steam hose to steam valve.
4. Connect the cable to the steam coil.
5. Fit rear cover back to its original place.

Supply Dispensing

	WARNING
<p>Dangerous Chemicals. May damage eyes and skin. Wear eye and hand protection when handling chemicals; always avoid direct contact with raw chemicals. Read the manufacturer's directions for accidental contact before handling chemicals. Ensure an eye-rinse facility and an emergency shower are within easy reach. Check at regular intervals for chemical leaks.</p>	
W363	

Supply Dispensing	
Number of external liquid supply connections	8
Liquid supply connection size, in. [mm]	5/16 [8]
Number of diluted liquid soap supply connections	3
Diluted liquid soap supply connection size, in. [mm]	1/2 [12]

Table 28

IMPORTANT: Always use liquid soap pumps with a flow that bring the requested quantity in less than 30 sec.

IMPORTANT: Start pumping immediately after water valves are open. The incoming water dilutes the liquid soap and brings it into the tub assembly.

Secure the location of the wiring and hoses so they can not be pinched, damaged or rubbed. Before you start to use liquid soap, check with your liquid soap supplier whether the liquid soap is harmless and inert to PP and PVC material in order to avoid damage to machine.

IMPORTANT: Failure to follow these instructions could damage the machine and void the warranty.

Connection of External Liquid Supplies

1. Facing the rear of the machine, locate the eight (8) 5/16 inch [8 mm] supply hose connections found on the left-hand side of the valve panel. Refer to *Figure 31*.

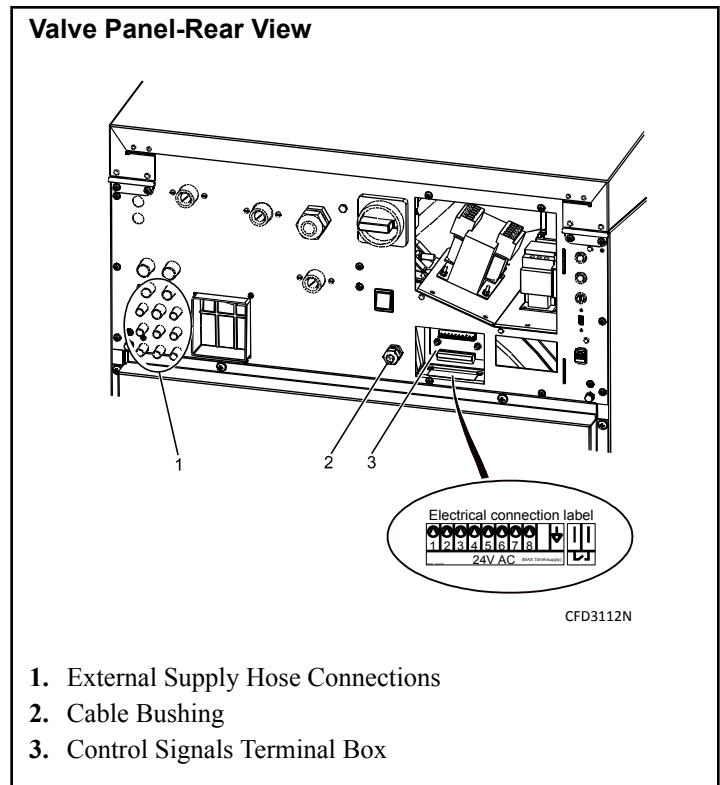

2. Drill through the eight (8) plastic holes on the valve panel for the external supply hoses as needed.

NOTE: On the valve panel by the external supply hose connections are three (3) connections of 1/2 in. 12 mm that are to be used only for entering diluted soap. To use, drill a 7/16 inch 11.5 mm hole only in connections that will be used.

3. Remove plastic debris.
4. Attach the external supply hoses to the ports at each of the drilled holes.
5. Secure with proper clamps.

	WARNING
<p>Check that the hose connections are tight (check the clamps). Any chemical leakage may cause serious bodily injuries as well as serious damage to the washer. If one of the connections is open, close and secure the opening with an appropriate cover.</p>	
W909	

NOTE: Do not attempt to make chemical injection supply pump electrical connections to points other than those provided specifically for that purpose by the factory.

Electrical Connection of External Liquid Soap Supply System

The power supply of the external liquid soap supply system has to be connected to an external electrical source. Only authorized workers with valid qualifications must execute the electrical connection on the machine according to valid local standards. The correct connection can be found on the wiring diagram included with the machine. Do not connect the liquid soap pump system in the washer.

The electric connection for supply control signals is available on the rear panel. Refer to *Figure 31*. At the terminal box, there is a label for electric connection. Detail on connection of signals can also be found on the electric scheme of the machine.

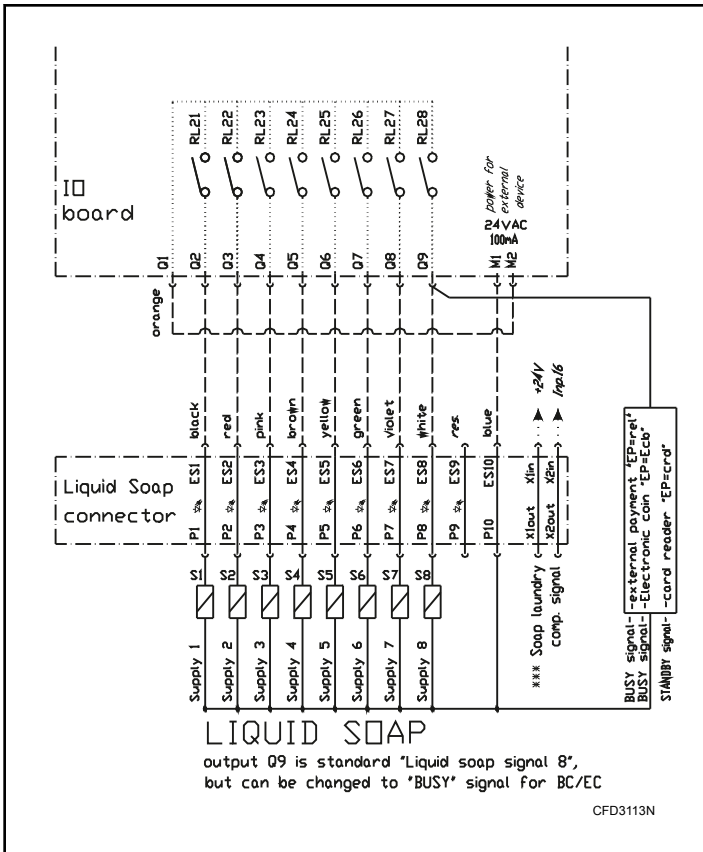

Figure 32

Signals for supply pump control are 24 VAC. Maximum current for control circuits of pump must be limited to 100mA. Lead the cable for connection of pump control signals through the plastic cable bushing. After connection of conductors to the respective positions of the connector "P", fix up the cable by tightening the cable bushing against disconnections and close the box with the cover. For details about liquid soap supply system programming, refer to Programming Manual.

Operation

Operating Instructions

1. Turn on main power source (circuit breaker).
2. Pull on the door handle to open the door.
3. Load to capacity whenever possible. DO NOT OVERLOAD. Refer to *Figure 33*.

NOTE: Underloading can cause out-of-balance conditions that can shorten machine life.

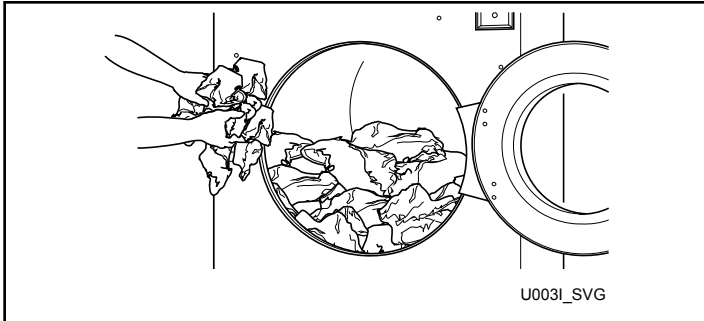

Figure 33

4. Close the door by applying moderate pressure on the door handle and simultaneously turning door handle partially to the left.

NOTE: Make sure the door is closed properly before operating washing machine. Do not turn the handle completely around or the safety system will not engage. The safety system serves as protection against violent handling and damage to the door lock while the machine is operating.

5. Choose the desired wash program best corresponding to the quality of the garments and allowed wash temperature in the wash load.

	WARNING
To prevent personal injury, avoid contact with inlet water temperatures higher than 125° Fahrenheit [51° Celsius] and hot surfaces.	
W748	

	WARNING
Water cannot be extracted from rubber backed items. To avoid damage to machine from out of balance conditions, do not use a spin (extract) step when washing rubber backed items. Warranty will be voided.	
W880	

6. Add liquid supplies to supply dispenser and close lid.

NOTE: It is advisable to use only detergents with "softener to break the suds", which can easily be found in retail shops. Do not use gel detergents. The dosage of soap is generally mentioned on the packing. An overdose of detergent can lead to poor wash results and suds or overflow which can damage the machine.

1. Detergent for the pre-wash
2. Detergent for the main wash
3. Liquid detergent for the main wash or liquid bleach, etc.
4. Liquid fabric softener or liquid starch for the last rinse

Figure 34

7. For vended models only, insert coin(s) or card as necessary.
 - If the machine is a coin operated unit, add coins. As each coin is added, the vend counts down to the amount remaining.
8. Press the START keypad.
9. During first 150 seconds, the desired wash cycle can be changed. After first 150 seconds have ended, the wash cycle active at that moment remains the chosen wash cycle.
10. The wash cycle time is counted down to zero on the display. After completion, the door lock unlocks and the display shows "UNLOAD".

	WARNING
<p>If, after a power disconnect, the machine door cannot be opened and the machine is fitted with an automatic unlocking circuit, wait until the locking circuit unlocks the door lock. Before you open the door, make sure that the drum is completely still and all water has drained.</p>	
W903	

	WARNING
<p>The automatic door-lock unlocking module must not be utilized on machines that are fitted with a drain pump or reverse function drain valve.</p>	
W910	

Power Cut

If a power cut occurs in an idle condition of the machine and no wash program is running, the machine remains in the idle condition.

Models without numeric keypad

If a power cut occurs during the wash process and the door remains closed and locked, the wash program will, after the power supply has been restored, automatically continue in the program beginning from the step in which the program was interrupted.

For machines fitted with an automatic door-lock unlocking module, refer to *Automatic Door-lock Unlocking Module* section. If during the power cut, the door lock gets unlocked and the door remains closed, the message "PRESS START / OPEN DOOR" appears as soon as the power supply is restored. If you open the door, the wash program will be cancelled. If you press the START button, the wash program will continue beginning from the step in which the program was interrupted.

Models with numeric keypad

If a power cut occurs during the wash process, the message "CONTINUE / STOP" appears as soon as the power supply is restored. If you press the STOP button, the wash program will be cancelled. If you press the START button, the wash program will continue beginning from the step in which the program was interrupted.

Automatic Door-lock Unlocking Module

Some machines are fitted with an automatic module for unlocking the door lock in case of a power cut.

If a short term power cut occurs, this module does not affect the operation of the machine.

If a long term power cut occurs, the module unlocks the door lock. It is then possible to open the door and remove laundry.

Maintenance

Maintenance

	WARNING
<p>Use the proper chemical agents which avoid calcium sediments on heating elements and other machine parts. Discuss the issue with your supplier of washing products. The manufacturer of the machine is not responsible for the damage of heating elements and other machine parts due to calcium sediments.</p>	
W904	

	WARNING
<p>Sharp edges can cause personal injury. Wear safety glasses and gloves, use proper tools and provide lighting when handling sheet metal parts.</p>	
W366R1	

IMPORTANT: Replace all panels that are removed to perform service and maintenance procedures. Do not operate the machine with missing guards or with broken or missing parts. Do not bypass any safety devices.

Daily

IMPORTANT: Replace all panels that are removed to perform maintenance procedures. Do not operate the machine with missing guards or with broken or missing parts. Do not bypass any safety devices.

	WARNING
<p>Do not spray the machine with water. Short circuiting and serious damage may result.</p>	
W782	

IMPORTANT: Door lock should be checked daily to ensure proper operation. Also check that all safety and instruction stickers are on the machine. Any missing or illegible safety instructions stickers should be replaced immediately.

Beginning of Day

1. Check door interlock before starting operation:

- a. Attempt to start the machine with the door open. The machine should not start.
- b. Close the door without locking it and start the machine. The machine should not start.
- c. Attempt to open the door while the cycle is in progress. The door should not open.

If the door lock and interlock are not functioning properly, disconnect power and call a service technician.

2. Check the machine for leaks.
 - a. Start an unloaded cycle to fill the machine.
 - b. Verify that door and door gasket do not leak.
 - c. Verify that the drain valve is operating and that the drain system is free from obstruction. If water does not leak out during the first wash segment, the drain valve is closed and functioning properly.
3. Inspect water inlet valve hose connections on the back of the machine for leaks.
4. Inspect steam hose connections for leaks (if applicable).
5. On machines equipped with an automatic Chemical Supply System, check all the hoses and hose connections for leaks or visible signs of deterioration. Replace immediately if either are present. Chemical leaks can cause damage to the machine's components.

	WARNING
<p>To reduce the risk of electrical shock, serious injury or death, disconnect the electrical power to washer-extractor before examining the wiring.</p>	
W636	

6. Verify that insulation is intact on all external wires and that all connections are secure. If bare wire is evident, call a service technician.
7. Ensure all panels and guards are properly installed.

End of Day

1. Inspect and clean the basket and door gasket of residual detergent and all foreign matter.
2. Clean the door glass and between the door gasket and the door with a damp cloth.
3. Clean supply dispenser lid and general area with mild detergent. Flush the dispenser with clean water.
4. Clean the machine's top, front and side panels with all-purpose cleaner. Rinse with clean water and dry.

IMPORTANT: Use only isopropyl alcohol to clean graphic overlays. Never use ammonia-based, vinegar-based or acetone-based cleaners on graphic overlays.

NOTE: Unload the machine promptly after each completed cycle to prevent moisture buildup. Leave loading door and dispenser lid open at the end of each completed cycle to allow moisture to evaporate.

5. Leave the loading door open at the end of each day to allow moisture to evaporate.
6. Shut off water supply.

Quarterly

NOTE: Disconnect power to the machine at its source before performing the quarterly maintenance procedures.

1. Check the bearing house for leakage.
2. Verify that the drain valve is operating and that the drain system is free from obstruction. If water does not leak out during the first wash segment, the drain valve is closed and functioning properly.
3. Visually check all hoses and connections inside machine for leaks.
4. Make sure that control components are protected against moisture and dust during the clean up. Wipe and clean the machine inside.
5. For models with electric heat, check the tightening of the contacts of heating elements terminals and other power terminals (main switch, fuse disconnectors, contactors).
6. In order to increase the service life of the door gasket, apply a glycerine-based impregnating agent.

Every 6 Months

NOTE: Disconnect power to the machine at its source before performing maintenance procedures.

1. Clean the water valve filters.

	WARNING
Before you start cleaning the water filters, make sure all water inlets to machine are closed.	
W907	

- a. Turn off the water supply.
- b. Unscrew the hoses at the back of machine.
- c. Take out filter at center with pointed pliers.
- d. Clean the filter and re-insert.
- e. When reattaching the hoses, make sure the seals are seated correctly.

- f. Check water inlets for leaks.
 - g. Tighten the connections or replace the seals of inlet hose if necessary.
2. If machine is fitted with a drain pump, make sure the pump provides normal flow rate during draining. The drain pump can be cleaned when it becomes clogged with foreign objects.
 - a. Drain all water from machine.
 - b. Disconnect machine from power supply.
 - c. Remove the front panel of cabinet by unlocking bolts. Refer to *Figure 35*.

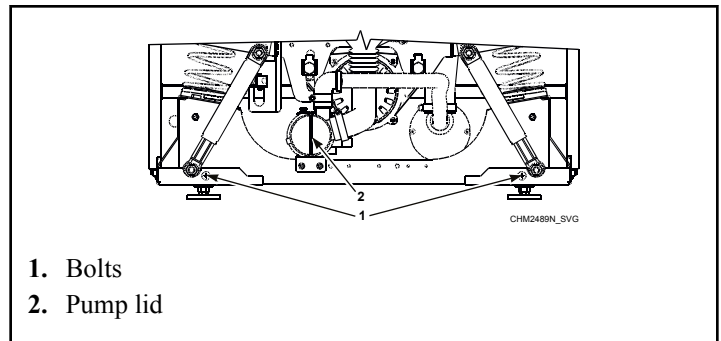



Figure 35

- d. Slightly turn the pump lid until water starts flowing out, making sure to catch the water.
 - e. Unscrew the lid and remove any foreign objects.
 - f. Reattach pump lid and front panel of cabinet.
3. Remove dust or dirt and verify functionality of the following:
 - a. Inverter cooling fin

	WARNING
Before removing top or back panel of machine, switch power off and wait for at least 10 minutes. Before starting inspection of frequency inverter, check for residual voltage across main circuit terminals. This voltage must be below 30 VDC before you can access the inverter for inspection.	
W905	

- b. Motor cooling fins
 - c. Interior inverter ventilator (if present)
 - d. Exterior inverter ventilator (if present)
- IMPORTANT: All torque joints must remain dry (non-lubricated).**
4. Check for belts for wear and inspect tightness. For recommended values, refer to *Table 29*.

Model	Torque, Hz
7 kg / 14 lb. / 65 L	67 - 70
8 kg / 20 lb. / 80 L	67 - 70
11 kg / 25 lb. / 105 L	65 - 68
14 kg / 30 lb. / 135 L	79 - 83
18 kg / 40 lb. / 180 L	64 - 69
24 kg / 55 lb. / 240 L	72 - 75
28 kg / 70 lb. / 280 L	72 - 75

Table 29

5. Check the tightness of bolts. Refer to *Table 30* .

Item	Bolt Type	Torque, lb. ft. [Nm]
Bolts of the dampers	M10	17.70 [24]
Bolts of the weight	M8	19.18 [26]
Door lock bolts	M5	1.84 [2.5]
Door handle central bolt	M6	6.49 [8.8]
Door hinge and front panel bolts	M6	6.49 [8.8]
Anchoring bolts	M16	73.76 [100]
External tub bolts - 18 - 28 kg / 40 - 70 lb. / 180 - 280 L Models	M8	19.18 [26]
External tub bolts - 7 - 14 kg / 14 - 30 lb. / 65 - 135 L Models	M8	8.85 [12]
Motor bolts	M12	N/A
Spring holder bolts	M8	7.38 [10]

Table 30

6. Adjust the safety switch.

NOTE: The safety switch is an important component which must, if correctly adjusted, stop the machine when excessive movement and shaking occur due to an unbalance caused by improper distribution of linen in the washing drum or when the amount of laundry exceeds the machine capacity.

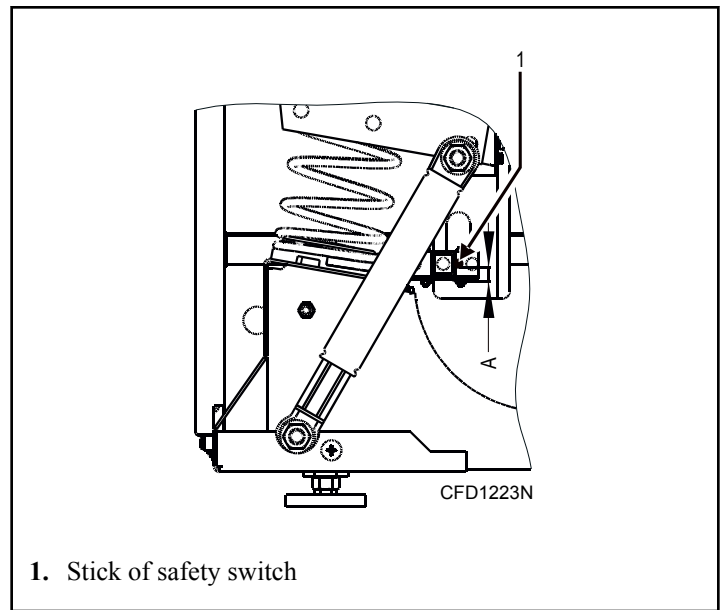

1. Stick of safety switch

Figure 36

Specification	Model	Requirement, in. [mm]
A - distance between lower edge of lug and stick of safety switch	7 kg - 14 kg / 14 lb. - 30 lb. / 65 L - 135 L	0.2 - 0.59 [5 - 15]
	18 kg - 28 kg / 40 lb. - 70 lb. / 180 L - 280 L	0 - 0.39 [0 - 10]

Table 31

Care of Stainless Steel

- Remove dirt and grease with detergent and water. Thoroughly rinse and dry after washing.
- Avoid contact with dissimilar metals to prevent galvanic corrosion when salty or acidic solutions are present.
- Do not allow salty or acidic solutions to evaporate and dry on stainless steel. Wipe clean of any residues.
- Rub in the direction of the polish lines or “grain” of the stainless steel to avoid scratch marks when using abrasive cleaners. Use stainless steel wool or soft, non-metal bristle brushes. Do not use ordinary steel wool or steel brushes.
- If the stainless steel appears to be rusting, the source of the rust may be an iron or steel part not made of stainless steel, such as a nail or screw.
- Remove discoloration or heat tint from overheating by scouring with a powder or by employing special chemical solutions.
- Do not leave sterilizing solutions on stainless steel equipment for prolonged periods of time.
- When an external chemical supply is used, ensure no siphoning of chemicals occurs when the machine is not in use. Highly concentrated chemicals can cause severe damage to stainless steel and other components within the machine. Damage of this kind is not covered by the manufacturer’s warranty. Locate the pump and tubing below the machine’s injection point to prevent siphoning of chemicals into the machine.

Disposal of Unit

Disconnecting the Machine

1. Switch off the external electric power inlet to machine.
2. Turn off the main switch on machine.
3. Shut the external water or steam inlet to machine.
4. Make sure the external electric power and steam inlets are shut off. Disconnect all electric, water or steam inlets.
5. Insulate the external electric power inlet conductors.
6. Equip the machine with an "Out of Service" sign.
7. Unscrew nuts and bolts that fix machine to floor.
8. If the machine will never be used again, secure it so injury to persons and damage to health, property and nature is avoided. Remove the door, secure the drum so it does not turn and remove any sharp parts of machine so enclosure or injury of a person or animal will not occur.

household waste disposal service, or the source from which the product was purchased.

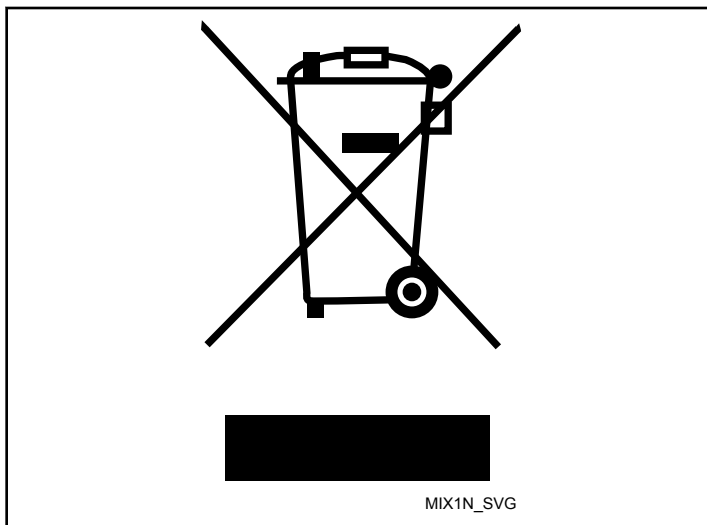

Figure 37

	CAUTION
<p>Be careful when disconnecting machine from service. Falling door and glass can cause injuries.</p> <p style="text-align: right;">W922</p>	

	WARNING
<p>Take all necessary action and precautions when disassembling the washer to avoid injury from glass or sharp metal edges.</p> <p style="text-align: right;">W908</p>	

Disposal of Unit

This appliance is marked according to the European directive 2002/96/EC on Waste Electrical and Electronic Equipment (WEEE).

This symbol on the product or on its packaging indicates that this product shall not be treated as household waste. Refer to *Figure 37*. Instead it shall be handed over to the applicable collection point for the recycling of electrical and electronic equipment. Ensuring this product is disposed of correctly will help prevent potential negative consequences for the environment and human health which could otherwise be caused by inappropriate waste handling of this product. The recycling of materials will help to conserve natural resources. For more detailed information about recycling of this product, please contact the local city office,